



[www.mortara.com](http://www.mortara.com)

REF 9516-171-50-ENG Rev D1

# ELI 350

12-LEAD RESTING ELECTROCARDIOGRAPH  
**SERVICE MANUAL**

Manufactured by Mortara Instrument, Inc., Milwaukee, Wisconsin U.S.A.



**CAUTION:** *Federal law restricts this device to sale by or on the order of a physician*



Copyright © 2007-2011  
by Mortara Instrument, Inc.  
7865 N. 86th Street  
Milwaukee, Wisconsin 53224

*This document contains confidential information that belongs to Mortara Instrument, Inc. No part of this document may be transmitted, reproduced, used, or disclosed outside of the receiving organization without the express written consent of Mortara Instrument, Inc. Mortara is a registered trademark of Mortara Instrument, Inc.*

## TECHNICAL SUPPORT AND SERVICE

---

### Headquarters

#### **Mortara Instrument, Inc.**

7865 North 86th Street  
Milwaukee, WI 53224  
U.S.A.  
Tel: 414.354.1600  
Tel: 800.231.7437  
Fax: 414.354.4760  
Internet: <http://www.mortara.com>

### European Union Representative

#### **Mortara Rangoni Europe, Srl**

(European Headquarters)  
Via Cimarosa 103/105  
40033 Casalecchio di Reno (BO)  
Italy  
Tel: +39.051.298.7811  
Fax: +39.051.613.3582

### Service/Technical Support Group

#### **Mortara Instrument, Inc.**

7865 North 86th Street  
Milwaukee, WI 53224  
U.S.A.  
Tel: 414.354.1600  
Service: 888.MORTARA  
(888.667.8272)  
Fax: 414.354.4760  
E-mail: [techsupport@mortara.com](mailto:techsupport@mortara.com)

24-hour Technical Support  
Same-day Shipment of Replacement Parts  
Biomedical Training Classes  
Extended Warranties/Service Contracts

### Sales Support/ Supplies & Accessories

#### **Mortara Instrument, Inc.**

7865 North 86th Street  
Milwaukee, WI 53224  
U.S.A.  
Tel: 414.354.1600  
Fax: 414.354.4760  
E-mail: [sales@mortara.com](mailto:sales@mortara.com)

#### **Mortara Instrument Germany**

Kaninenberghöhe 50  
45136 Essen  
Germany  
Tel: +49.201.18 55 69 70  
Fax: +49.201.18 55 69 77

#### **Mortara Instrument Netherlands**

Postbus 324  
5680 AH Best  
Randweg 4  
5683 CL Best  
Netherlands  
Tel: +31.499.377310  
Fax: +31.499.377908

#### **Mortara Instrument Australia**

PO Box 7568  
Unit 11, 7 Inglewood Place  
Baulkham Hills NSW 2153  
Australia  
Tel: +61 2 8824 5499  
Fax: +61 2 8814 5399

# Table of Contents:

<b>1</b>	<b>General</b>	
	User Safety Information .....	1-1
	Symbol Delineation .....	1-2
<b>2</b>	<b>Maintenance and Cleaning</b>	
	Preventive Maintenance Procedure.....	2-1
	Device Cleaning and Disinfecting.....	2-4
	Safety Testing.....	2-5
<b>3</b>	<b>Assembly/Disassembly of Unit</b>	
	Special Instructions and Cautions .....	3-1
	Base Unit assembly / disassembly .....	3-2
	Base assembly parts list .....	3-36
	LCD assembly / disassembly .....	3-37
	LCD assembly parts list .....	3-53
	Writer assembly / disassembly .....	3-54
	Writer assembly parts list .....	3-66
<b>4</b>	<b>Troubleshooting and Testing</b>	
	ELI350 Troubleshooting .....	4-1
	ELI350 Testing .....	4-3
	Cue Sensor Adjustment .....	4-4
	Modem Country Codes .....	4-8
	Safety Tests .....	4-9
<b>5</b>	<b>Options &amp; Upgrades</b>	
	Upgrade Options .....	5-1

## 1 General

### ***Service Manual Purpose***

The purpose of this manual is to supply information to service personnel so they can maintain the ELI 350 Electrocardiograph at the assembly and subassembly level. Although the manual includes parts lists, mechanical assembly parts, and printed circuit board information, it is intended to function primarily as a guide to preventative and corrective maintenance and electrical repairs considered field repairable.

### ***User Safety Information***

#### ***Periodic Safety Inspections***

Follow the recommended maintenance schedule. Inspect the power cord and transmission cables periodically for fraying or other damage and replace as needed. Broken or frayed wires may cause interference or loss of signal. Pay particular attention to points where wires enter connectors.

#### ***Proper Power Cord***

Use only the power cord specified for the equipment. This product requires a three-wire, (18 gauge, SJT-grade) power cord, which is supplied with a three-terminal, polarized plug (hospital grade) for connection to the power source and protective ground. Use only a power outlet with a protective ground outlet. An interruption of the grounding connection could cause an electrical shock hazard.

#### ***Proper Fuse***

Use only the fuse specified for the equipment (identical in type, voltage and current rating). Substituting a different fuse type could cause a fire hazard. Always make sure fuses have been installed before operating the unit.

#### ***Do Not Operate in Explosive Atmospheres***

Do not operate the ELI 350 in the presence of flammable gasses or anesthetics; this environment could cause an explosion. Refer to Operator's Manual Safety Information: Warning(s) and Caution(s).

#### ***Use Only Safe Methods of Interconnection***

To prevent electrical shock from the product when it is connected to other electrical equipment, proper grounding is essential. Refer to Operator's Manual Safety Information: Warning(s) Peripheral equipment.

#### ***Do Not Mount Product above Patient***

Do not mount or place the product where it could fall on a patient or where it could be accidentally knocked off a shelf or other mounting arrangement.

#### ***Recommended Accessories***

For the patient's safety and optimum equipment performance, use only the accessories specified by Mortara Instrument, Inc.

### **Sterilizing this Product**

Do not sterilize this product or any accessories unless specifically directed by the manufacturer. Sterilization and sterilization environments can seriously damage many components and accessories.

### **Liquid Spills**

Do not set beverages or other liquids on or near the ELI 350, and/or optional equipment.

### **Product Information**

Refer to the User's Manual

### **Manual Symbol Delineation**



*Electrostatic sensitive devices*



*Caution or Special Instructions*

## 2 Maintenance and Cleaning

### Preventive Maintenance

Preventive maintenance is recommended to be performed on the ELI350 cardiograph once every 12 months.

A preventive maintenance report to document the maintenance activity performed is located at the end of this section of the manual.



**Warning:** *Preventive maintenance is to be performed by Mortara authorized service personnel only.*

### Maintenance Procedure:

- Turn on the cardiograph and print the unit configuration information from the “System Settings” page.
- Remove the upper housing per section 3 of this manual.
- Remove the four (4) screws from the writer assembly, without disconnecting the cables, to perform the complete visual inspection below.
- Perform a visual inspection of the following items:
  - Enclosure/Housing – Look for damage or cracks in the external housing or enclosure that could possibly expose the device to the introduction of foreign objects or fluids. Attention should also be paid to areas that could expose an operator or patient to internal circuitry of the device.
  - Contamination – Look for any contamination that may have occurred over time that could not be seen with the housing in place.
    - Fluid damage (perhaps caused during device cleaning)
    - Debris on or behind display shield
    - Battery leakage (lithium and main battery)
  - Internal Cabling – Look for cracked, pinched or partially disconnected cable connections.
  - Fuse Ratings – Verify the battery and AC line fuses match the device labeling.
  - Markings and Labeling – Verify all labels and device markings are clearly visible and legible to the device user and have not been worn off or rendered unreadable through the use of harsh cleaning agents.
  - Integrity of Mechanical Parts – Verify the following items are properly secured to the device and have not become loose or damaged through usage over time.
    - AC Inlet
    - Patient Input Connector
    - Communication ports and antenna
    - Writer mechanics/latching mechanism
    - LCD Assembly

- **Power Testing**

- Note battery age (if possible)

*This information can be found on the “date code” sticker on the battery (use the earliest date crossed out on the label); or on a sticker located on the bottom of the unit.*

*Based upon customer usage, and the age of the main battery, replace as needed and place a sticker on the bottom of the unit to identify when the battery was replaced.*

*If the internal lithium battery is older than 5 years it should be replaced and a sticker should be placed on the bottom of the unit to identify when the lithium battery was replaced.*

*Ensure the battery is fully charged before performing the battery tests; the test limits are based on a fully charged battery.*

*Disconnect the AC power cord to begin this section of tests.*

*With the upper housing off of the unit, disconnect the battery cable from the positive terminal.*

- Battery Open Circuit – Measure the open circuit battery voltage using a volt meter across the battery terminals, the meter should read greater than 12.5vdc.
- Battery w/Load – Measure the battery voltage using a volt meter with a power resistor load (10ohm, 20watt) across the battery terminals. After loading the battery for approximately 5 seconds, the meter should read greater than 11.7vdc.
- Off Current – Connect a current meter in line with the positive battery terminal to the motherboard. With the unit in the “off” state the meter should read less than 450 micro amps.
- On Current – Set the current meter to a setting greater than 5 amps, and turn the unit on. Once the unit powers up to the main menu, the current should read less than 2.7 amps.
- AC Charging Current – Insert the AC power cord and verify that the current draw from the battery reverses polarity (starts to charge the battery) and the value starts decreasing in magnitude as time increases.
- Battery Charger Output Voltage – Disconnect the current meter and measure the battery charger output voltage between the disconnected positive battery cable and the negative battery terminal. It should read between 13.0 and 14.0vdc.

Reconnect the battery cable to the positive terminal and verify all other internal cables are properly connected. Install the writer assembly screws and the upper housing on the cardiograph.



## • Functional Testing

- AC/DC LED
  - Connect a power source to the AC inlet of the UUT. Verify the AC LED on the keyboard illuminates continuous. With the display in the upright position, turn the unit on. The BATTERY LED will illuminate continuously if the battery is charging, it will turn off when the battery is fully charged or when the display is completely lowered.
- LCD/Tilt Switch
  - Verify the LCD backlight is on and there are no flickering or missing lines/pixels.
  - Slowly lower the LCD, verify the backlight turns off before or it is completely lowered. Raise the LCD and verify the backlight turns back on.
- Writer
  - Open and close the writer drawer. Verify smooth operation of the drawer. Verify that the drawer unlatches without sticking. Verify that the drawer latches completely.
  - From the main screen, click on SETTINGS, enter PASSWORD "Print test" and then press the Enter key. Verify that a test page is printed and the writer stops on the cue mark. The perforation on the paper should line up with the tear edge on the UUT. Assure there are no gaps in the print and darkness is uniform across the entire page. Verify no gear skipping and proper paper tracking as the writer prints (you might need to print 3 or more pages to verify this).
- ECG & Keyboard Matrix
  - Using a Mortara 10-lead patient cable, connect an ECG simulator to the UUT. Set the simulator to an appropriate heart rate and amplitude to enable visual confirmation of the correctness of the ECG printout (comparison to a sample printout from a "known good" device is recommended). Press the AUTO key to capture an ECG. Enter Last Name "PARCFL8", click on OK to continue and then print the ECG.  
  
*NOTE: "PARCFL8" ensures the keyboard matrix is fully tested. Verify there is an audible beep with each key press.*
  - Verify that 12 ECG traces print with the correct heart rate, amplitude and morphology, then assess the overall print out quality (ensure there is uniform darkness across entire printout).
- ECG Noise Test
  - Connect a Shorting Block (TF-0063) or equivalent to the UUT and set the ECG gain to 20mm/mV. Print a Rhythm strip (approx. 1 page). Verify that no channels have more than 0.5mm of baseline noise.
- Communication options
  - Transmit a test ECG record to a compatible receiving device for all of the applicable communication options enabled below:
    - Modem
    - LAN
    - WLAN

## Device Cleaning & Disinfecting



### Warning:

- Use of non-recommended cleaning agents or practices could cause damage to the device or possible compromising of the electrical isolation of the device.
- Make sure all cables and accessories are disconnected from the device prior to performing cleaning process.
- Do not immerse the device in liquid.
- Do not use organic solvents, ammonia-based solutions, or abrasive cleaning agents that may damage equipment surfaces.
- Do not use excessive amounts of liquid during cleaning or disinfecting of the device, as these fluids could enter the device housing and cause damage to the device.

### Recommended Supplies:

- Clean lint free cloth
- Mild detergent
- Luke warm water
- 10% Household bleach and water solution (Sodium Hypochlorite solution consisting of a minimum 1:500 dilution and maximum of 1:10 dilution for disinfecting use only)
- Isopropyl alcohol or alcohol wipe

### Device Cleaning:

Disconnect the AC power cord from the device. Clean the exterior surface of the device with a damp (not wet), soft, lint-free cloth using a solution of mild detergent diluted in luke warm water. After cleaning, thoroughly dry off the device with a clean, soft cloth or paper towel.

Open the writer door and wipe the thermal print head clean with a moist alcohol pad and allow it to air dry.

### Device Disinfecting:

Clean the device per the instructions defined above, then wipe the exterior of the device with a damp (not wet), soft, lint-free cloth using a solution of 10% bleach and water. Allow the device to air dry after disinfecting before returning to use.

## Safety Testing

The following safety tests should be performed in accordance with IEC 60601 or IEC 62353 standards and all local regulatory requirements:

- Earth Leakage
- Enclosure Leakage
- Patient Leakage
- Patient Leakage Type-F
- Patient Auxiliary Current



# ELI350 Preventive Maintenance Report

Unit Serial #: \_\_\_\_\_

- Print device configuration
- Remove upper housing and writer assembly
- Perform Visual Inspection
  - Enclosure/Housing
  - Contamination
  - Cabling
  - Fuse Ratings
  - Markings and Labeling
  - Integrity of Mechanically Parts
- Power Testing
  - Note Battery Age (If Possible) \_\_\_\_\_ / \_\_\_\_\_ (week/year)  
*(Based upon customer usage and age of main battery, replace as needed)*
  - Battery Open Circuit Voltage \_\_\_\_\_ VDC
  - Battery Load Test \_\_\_\_\_ VDC
  - OFF Current \_\_\_\_\_ uA
  - On Current \_\_\_\_\_ A
  - AC Charging Current (reverses polarity and decreases in magnitude)
  - AC Charging Voltage \_\_\_\_\_ VDC
  - Check age of Lithium Battery (replace if older than 5 years)
- Verify all power cables are properly reconnected and reassemble unit
- Functional testing
  - AC/DC LED Operational
  - Display Functionality
  - Writer Test
  - ECG & Keyboard Matrix Testing
  - ECG Noise Test
  - Communication Options
- Device Cleaning
- Safety Testing PASS / FAIL (circle)
  - Earth Leakage
  - Enclosure Leakage
  - Patient Leakage
  - Patient Leakage Type-F
  - Patient Auxiliary Current

Technician or Field Service Engineer: \_\_\_\_\_ Date: \_\_\_\_/\_\_\_\_/\_\_\_\_

## 3 Assembly / Disassembly

### Special Instructions

The following section defines the assembly of the ELI350 electrocardiograph; disassembly should be performed by reversing the assembly process per these instructions.

This assembly procedure describes the use of Vibra-Tite on some threaded parts. The Vibra-Tite must dry for a minimum of 10 minutes before assembly. The Vibra-Tite may be applied to the threaded pieces ahead of time and allowed to dry. This way the parts will be available for assembly when needed. If the parts already have Vibra-Tite, this process can be skipped.

Before applying all adhesive backed materials, clean surface with alcohol to make sure it is clean and oil free.

Torque specifications for all fastening devices shall be 3.5-4.0 lbs-in, unless otherwise noted.

**Note:** Item numbers refer to the parts lists at the end of each assembly section.

### Cautions

**CAUTION: Risk of Explosion** - DO NOT SHORT Battery Terminals. Leave protective covers on the terminals until assembly into the base unit.

**CAUTION: Risk of Shock** – Line voltage may be present on the Motherboard. DO NOT touch components on the motherboard when performing confidence testing at the sub-assembly level.

**Caution: Risk of injury** – The ELI 350 weighs approximately 30 lbs. Use proper lifting techniques.

**ATTENTION:** The ELI 350 contains ESD Sensitive sub-assemblies. Observe ESD handling techniques when working with electronic assemblies.

**ATTENTION:** Pay particular attention to the positioning of the transformer wires on the motherboard to ensure the wires are not pinched during the assembly of the motherboard to the lower housing.

**ATTENTION:** Prevent pinching of all cables and harnesses by inspecting for proper routing during final assembly.

### LCD Display Sub-Assembly

Instructions for the assembly of the LCD display begin on page 3-35.

### Writer Sub-Assembly

Instructions for the assembly of the 8" thermal writer begin on page 3-52.

### Base Assembly

Note: Installation of optional communication hardware (Ref sections: *Modem Option, WLAN Option*) requires soldering components to the motherboard prior to installing the motherboard into the Base Assembly.

Note: It is recommended to apply all the applicable labeling (Ref section: *ELI 350 Labeling*) during the Base Assembly process.

Insert the blank bulkhead Front Closure Plate (Item 6) in to the Lower Housing (Item 3) and snap in place.

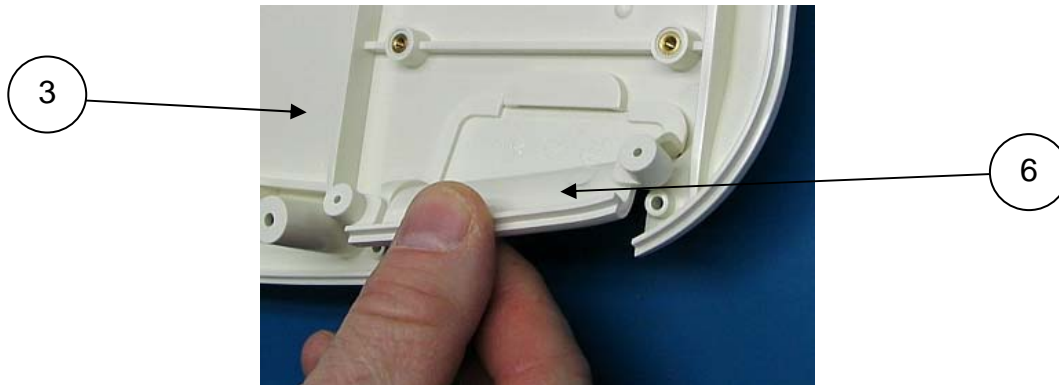

Flip the Lower Housing over and secure the Front Closure Plate to the Lower Housing using 2 screws (Item 30). Use a T9 bit. Torque Spec: Hand Tighten Only

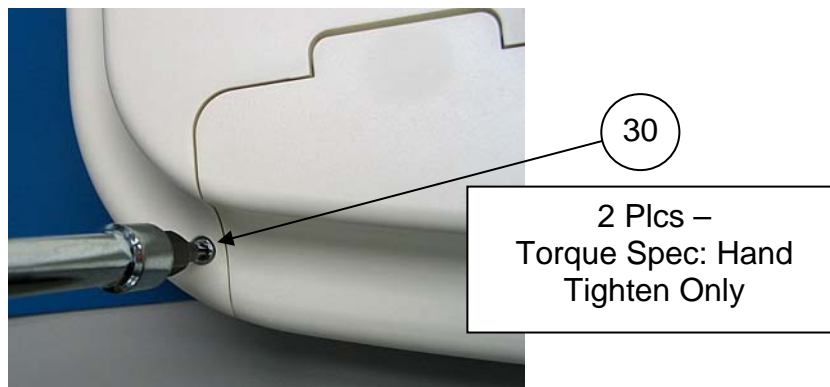

Apply the Rubber Feet (Item 22, 8 Plcs) to the Lower Housing in the recessed areas provided.

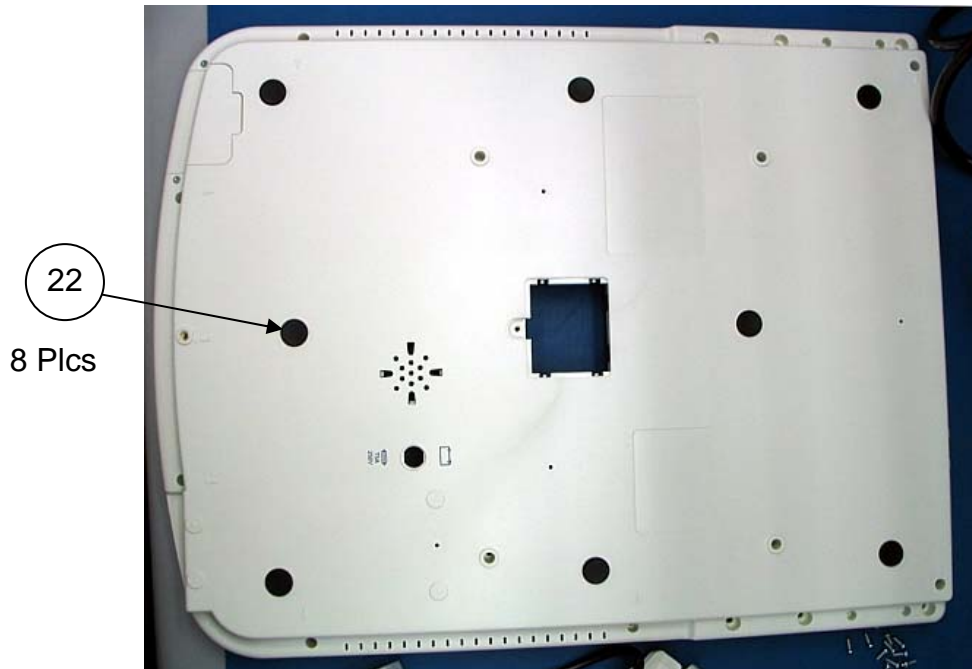

Insert the Fuse Holder Assembly (Item 17) and Fuse (Item 16 or 32 {see note below}) into the Lower Housing.

Ensure the Fuse Holder insert is fully clockwise and locked in place.

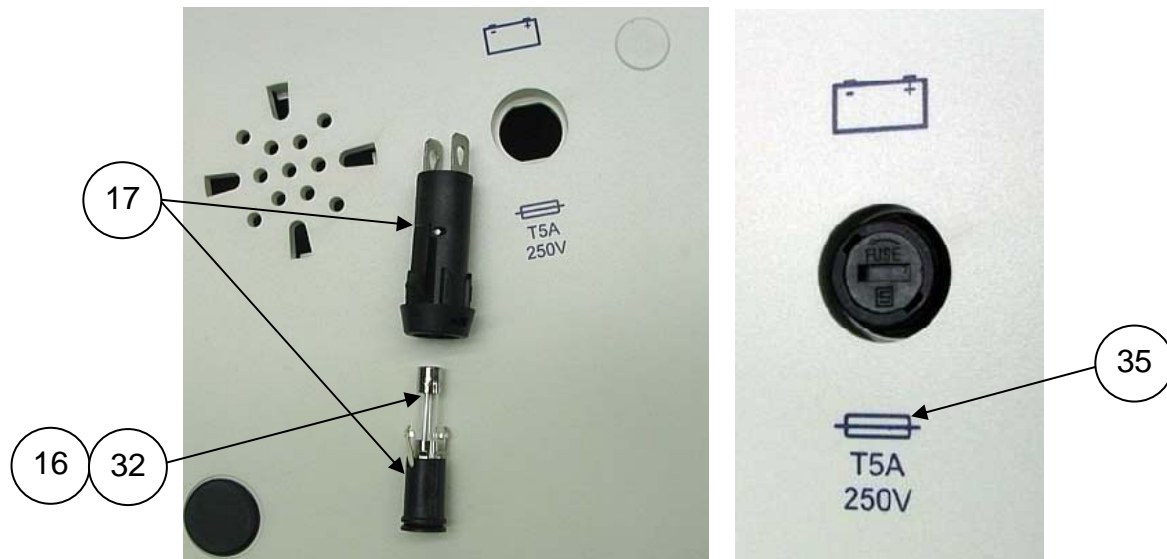

**IMPORTANT** – The battery fuse on the ELI350 unit is dependant upon the item number of the unit's motherboard. Units manufactured with the older motherboard (Item #26025-076-51) use a 5A fuse; and those manufactured with the newer motherboard (Item # 26025-076-52) use an 8A fuse. Fuse labeling shown above is for the 5A fuse application; fuse rating labels (Item # 35) are available to properly label the unit chassis if a fuse rating change is required, due to a motherboard service replacement.

Insert the SIM Card Access panel (Item 27) into the Lower Housing and secure with screw (Item 18).

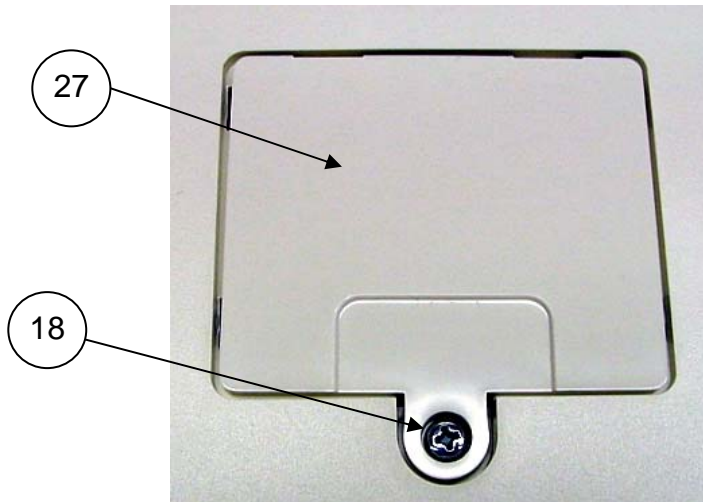

Flip the Lower Housing back onto the rubber feet. Insert the Speaker (Item 12) as shown. Remove the paper backing from one side only and secure the Speaker to the Lower Housing with a piece of Foam Tape (Item 23).





Install Front End PCB (Item 14) into Lower Housing and secure in place with 2 screws (Item 19) and 2 screws (Item 20).



If the 10K+ AUXILIARY PCB ASSY (Item 14a) is needed for the 15 lead option, install the 10K+ AUXILIARY PCB ASSY onto Front End PCB (Item 14) prior to installation of Front End PCB (Item 14) Assy.

***\*Note – This option can only be installed on the -52 and -53 motherboards; the hardware on the -51 motherboard does not support this option.***

### Communication Option Installation

Installation of optional communication hardware requires soldering components to the motherboard prior to installing the motherboard into the Base Assembly.

Additional items will also need to be installed depending on the required option

Ref sections: *Modem Option, WLAN Option* for installation instructions.

Apply Cable Tie Mount (Item 29) to bottom side of ELI 350 Motherboard under the LCD signal cable connector location as shown.

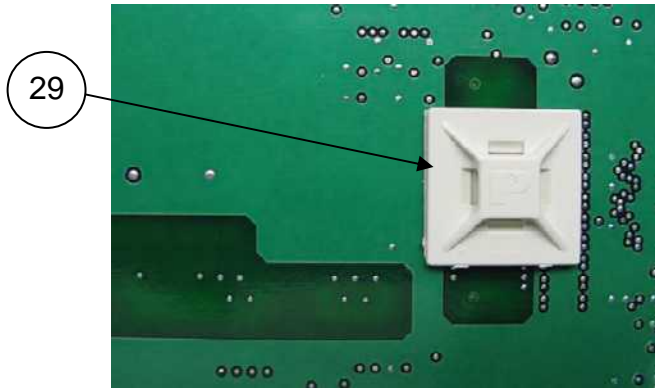

**CAUTION:** Motherboards labeled as item # 26025-076-51 (original PCB layout) utilize the transformer shown below. The transformer wires **MUST** be positioned away from the secondary circuit and any mounting bosses to ensure wires are not pinched during assembly. Motherboards labeled as item # 26025-076-52 utilize a different transformer design that eliminates the possibility of this potential hazard.

Bottom View

Top View

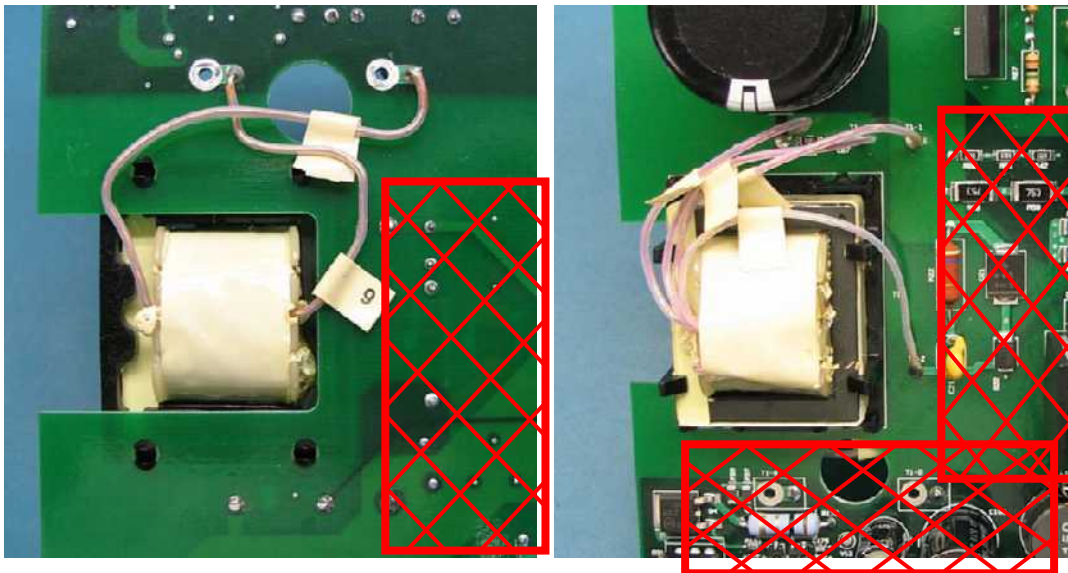

Install the ELI 350 Motherboard (Item 15) into the Lower Housing. Secure in place with 4 screws (Item 19) and 4 screws (Item 20).

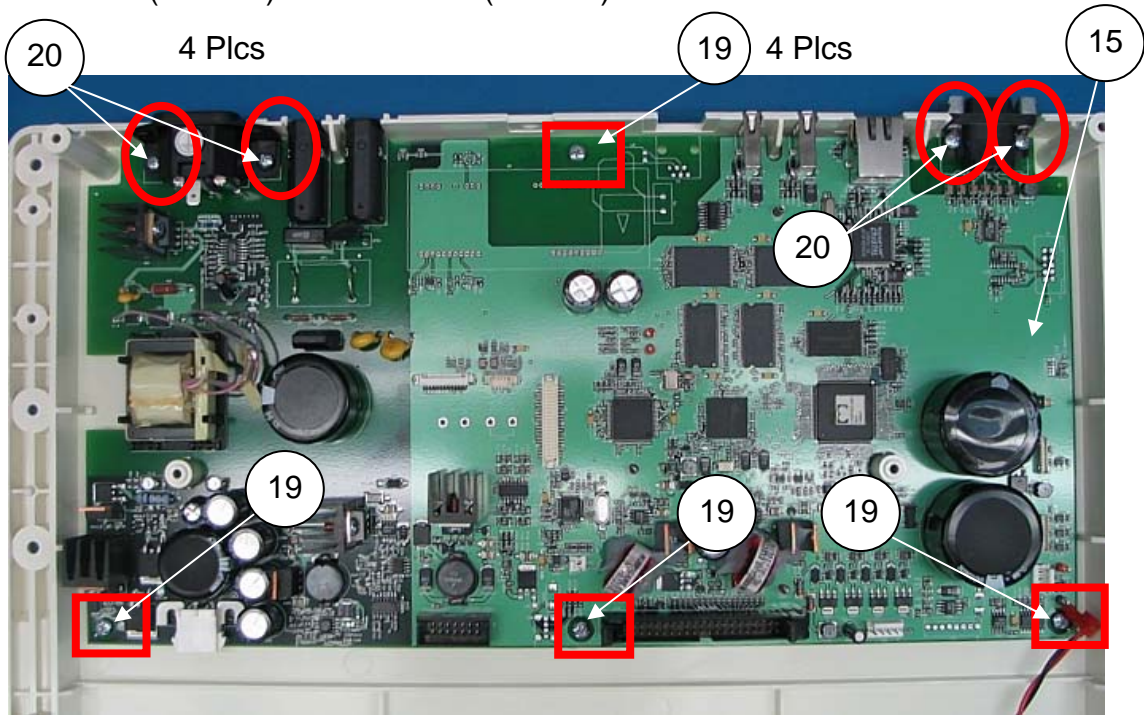

Ensure Lithium Battery is properly soldered to the Motherboard as shown.

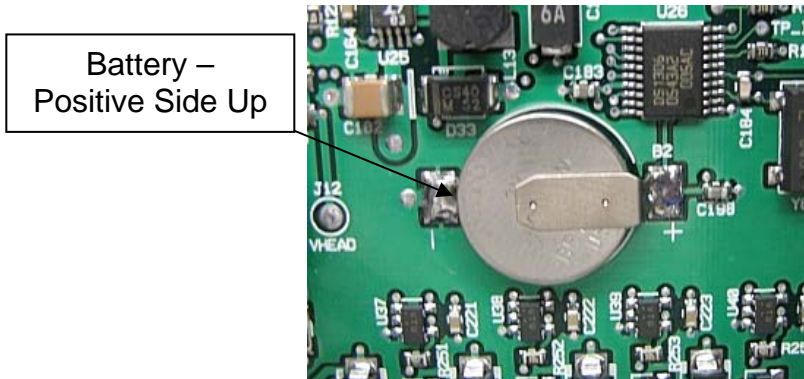

Ensure Power Line Fuses are installed and properly inserted into holder. Rotate the insert fully clockwise to lock the fuse in place.

Ensure Ground Label is applied to any of the flat surfaces of the AC Power Inlet connector.

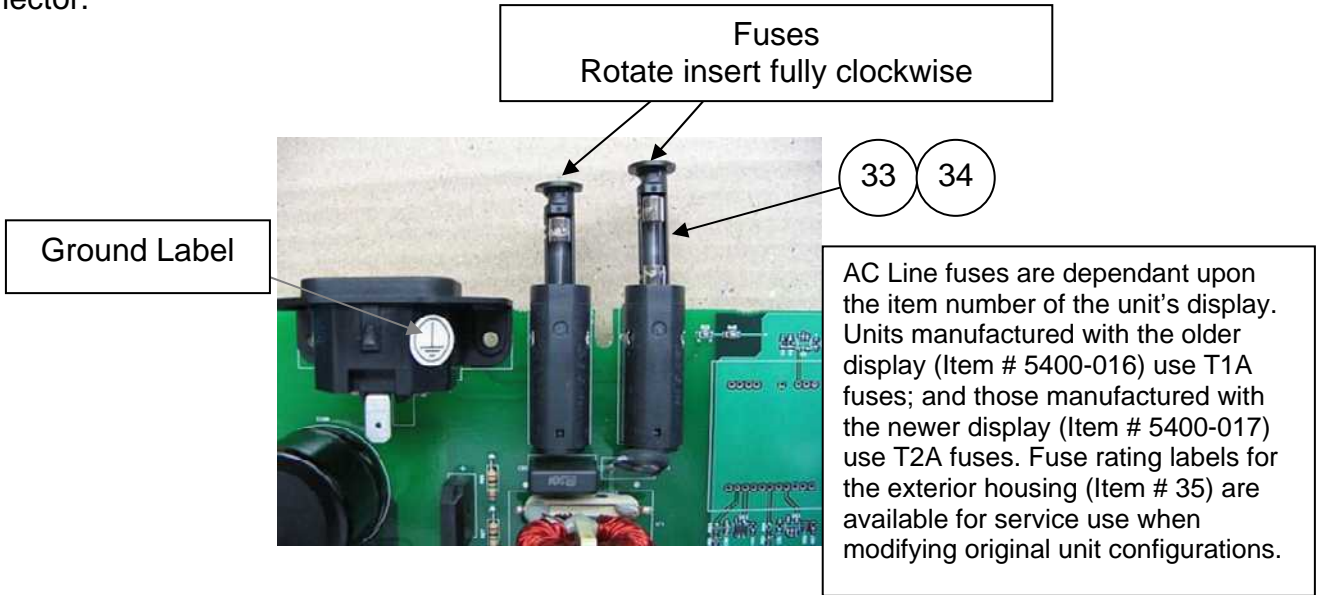

Install the Front End Ribbon Cable (Item 11). Connect each end to the applicable PCB assembly and route the cable as shown.

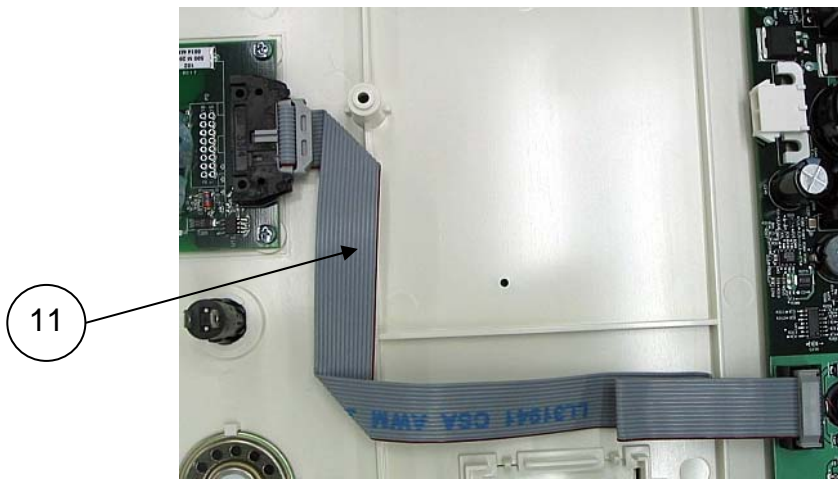

Connect the speaker to the Motherboard as shown.

Note: The cable will need to be routed away from the access cover if an optional GSM (Future) module is installed



Connect the Keyboard Ribbon Cable (Item 36) the Motherboard as shown. Ensure the short end on the Z-fold is the end connected to the Motherboard.



Install the cable retention clip (Item 26) inside the lower housing along the right side as shown. This will be used for routing the writer cables later in the assembly.

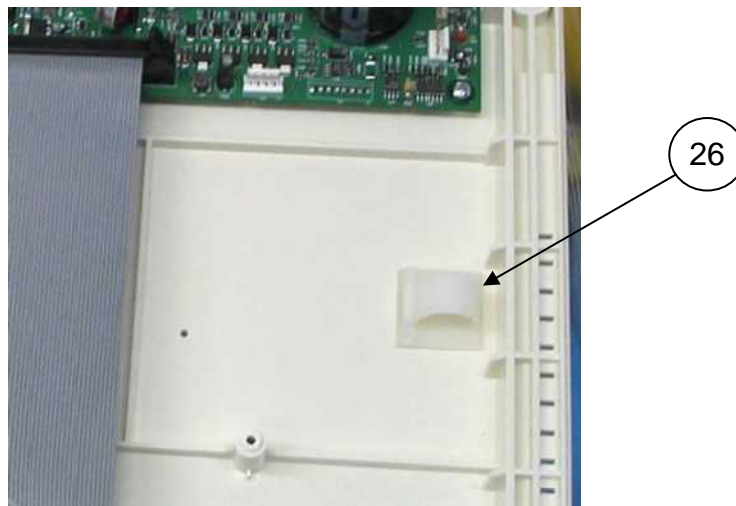

Apply 2 pieces of double sided tape (Item 23) to the Battery (Item 1), as shown. Note that the battery terminals are to the operator's right in this view.



Connect the Battery Cable (Item 13) to the battery as shown

Wire Color	Termination Type	Location
Red (Short Wire)	Fast-on Straight	(+) Battery Tab
Black	Fast-on Straight	(-) Battery Tab



Remove paper backing from double sided tape and install battery into the lower housing as shown. Note the orientation of the battery terminals to the fuse holder.

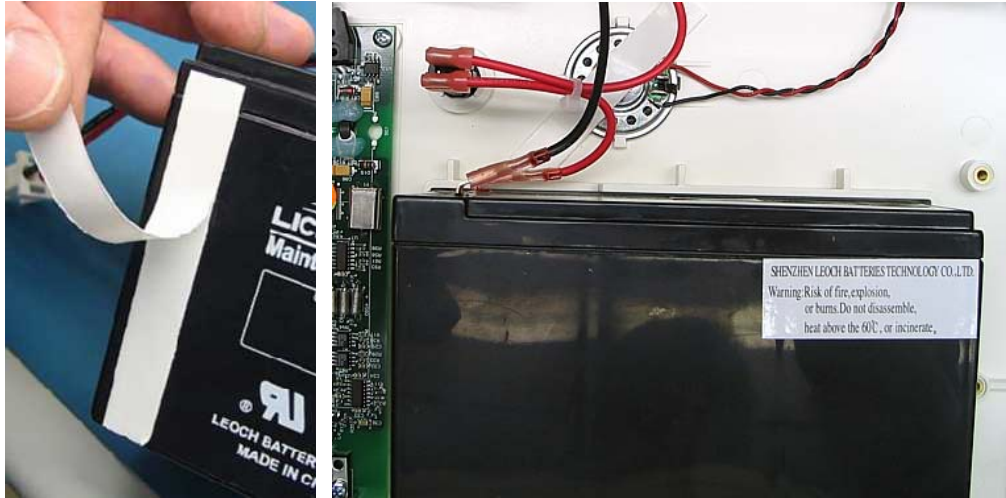

Connect battery cable to the fuse holder and Motherboard as shown.

Wire Color	Termination Type	Location
Red (Short Wire)	Fast-on Right Angle	Fuse Holder Tab Closest to battery
Red (Long Wire)	Fast-on Right Angle	Fuse Holder Tab Furthest from battery
Red/Black	Two pin connector	Mother Board P16



### **Top Cover Keyboard Assembly**

Note: Item numbers in this section refer to the parts on the applicable keyboard assembly.

For all keyboard options: Apply the LCD Bumpers (Item 9, 2 Plcs) to the Top Housing (Item 2), as shown.

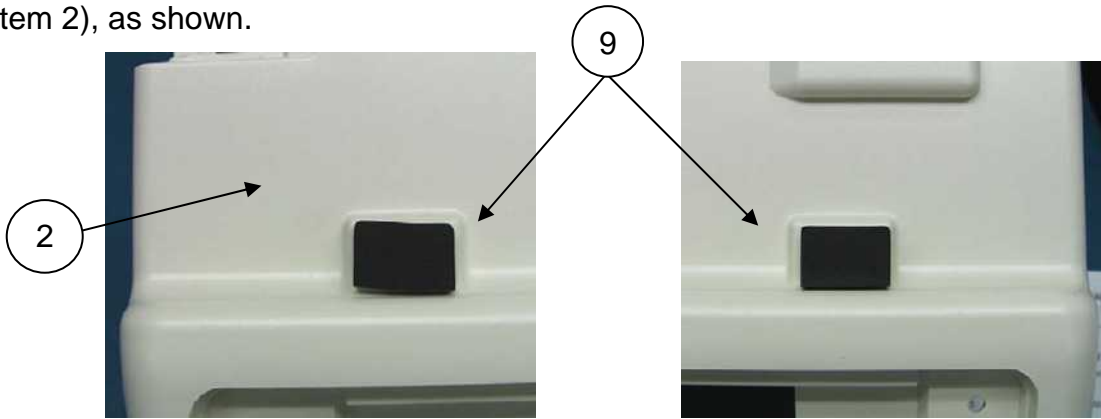

Option: *Click Knob keyboard Assembly*

Ensure Click Knob PCB is soldered to the keyboard PCB (Item 37) as shown.

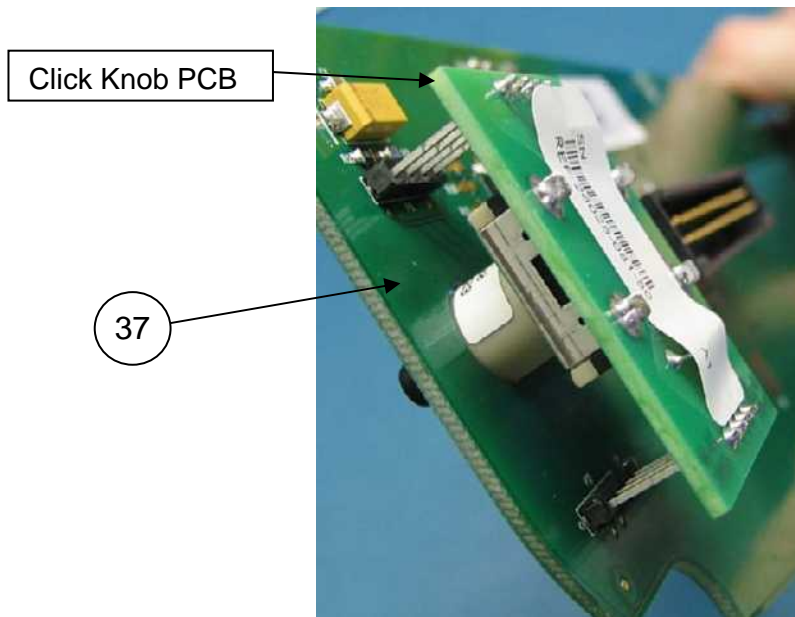



Apply the Elastomeric Keypad (Item 38) to the Keyboard PCB. Pull all alignment tabs (10 Plcs) completely through the keyboard PCB.

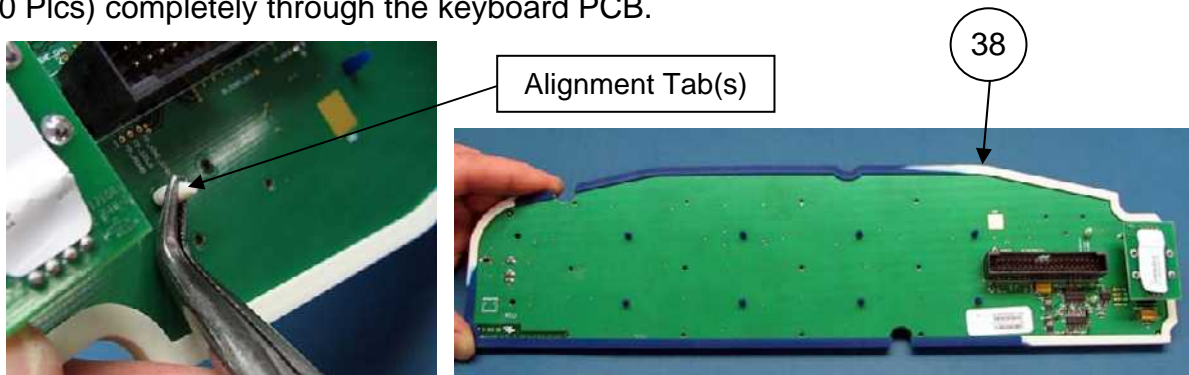

Apply Keyboard Bezel (Item 39) over the Elastomeric Keypad as shown. Ensure all keys extend through the applicable opening.



Apply the Battery / Power Label (Item 40) to the Keyboard Bezel.

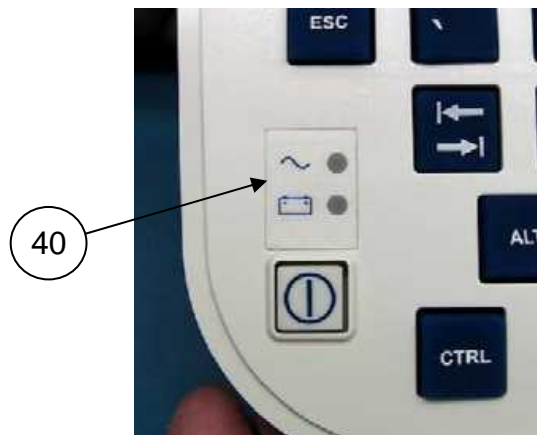

Apply the Click Knob (Item 41) to the keyboard assembly as shown. Ensure the knob is fully seated to the shaft of the assembly.

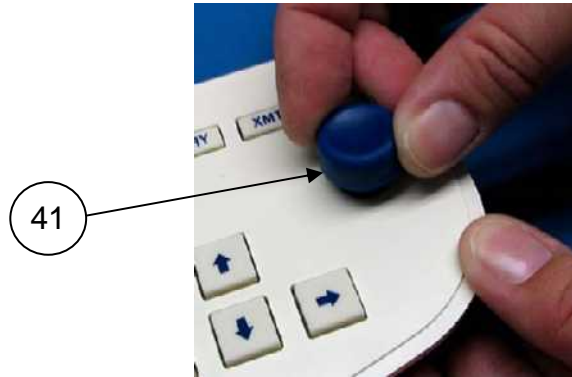

Apply the Keyboard Bezel Assembly to the Top Housing (part of the core BOM) as shown. Ensure the Bezel is centered in the opening.



Flip the assembly over and secure the keyboard bezel to the top cover with 6 screws (Item 20).

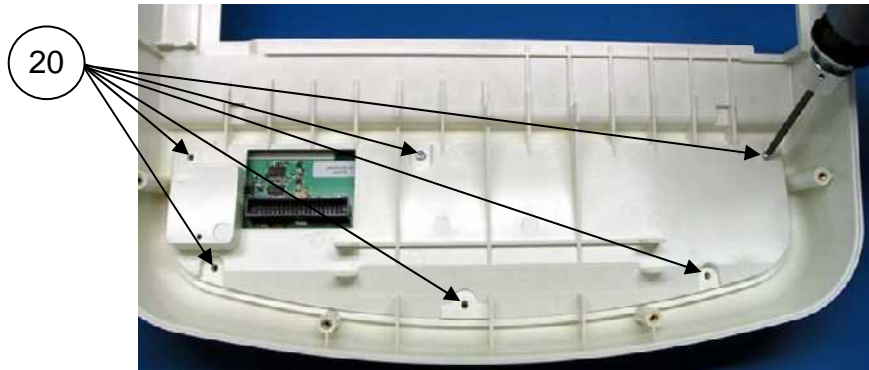

Option: *Touch Pad keyboard Assembly*

Apply the Elastomeric Keypad (Item 38) to the Keyboard PCB (Item 37). Pull all alignment tabs (10 Plcs) completely through the Keyboard PCB.

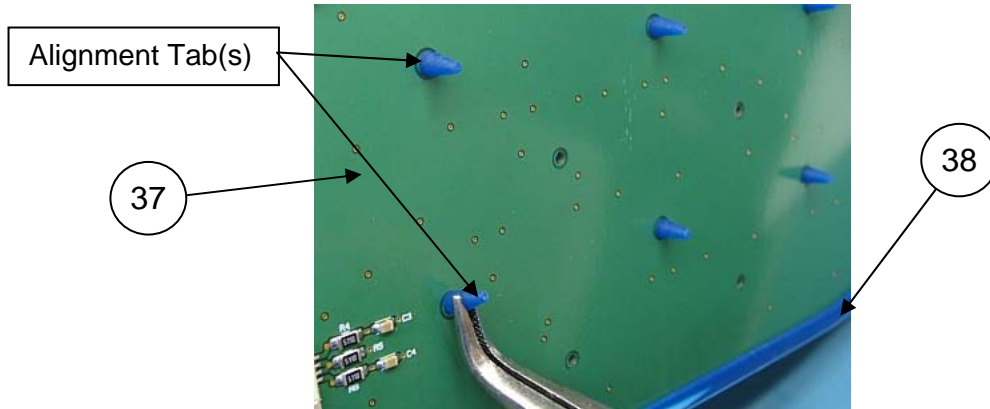

Connect USB cable to Touch Pad, as shown below.

Insert the flex circuit to the 4 pin connector located on the Touchpad electronic assembly, as shown.

Note: The flex circuit is oriented with the contacts up.

Note: The flex circuit is retained by the compression fit connector. DO NOT crease the flex circuit when inserting it into the connector.

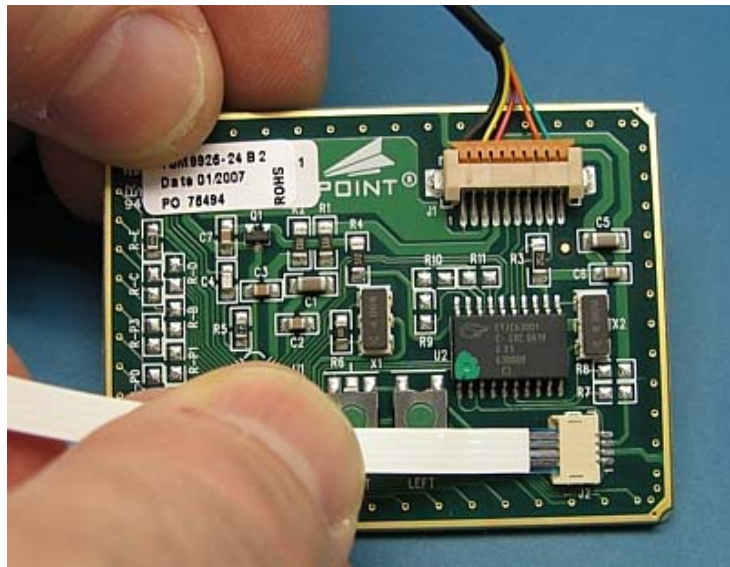

Insert the Touch Pad electronic assembly into the Keyboard Bezel in the orientation shown. Apply 2 pieces of Anti-Static Tape to retain the touch pad electronic assembly to the bezel during the assembly process.

Apply Anti-static tape along vertical edges 2 Plcs.



Feed the USB Cable and the flex circuit through the opening in the Keyboard PCB assembly. Pull up on J2 connector ears (on Keyboard PCB) to open connector. Insert the flex cable into the connector. Push the connector ears down as shown.

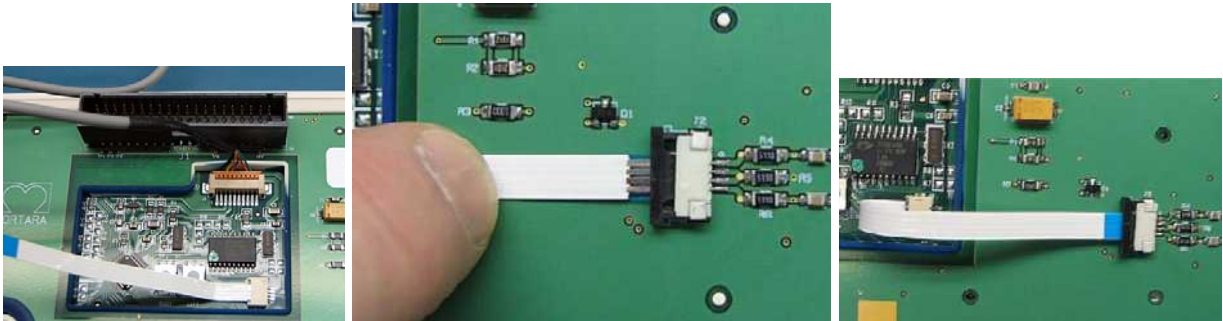

Flip the assembly over and apply the battery/ power label to the bezel



Apply the Keyboard Bezel Assembly to the Top Housing as shown. Ensure the bezel is centered in the opening.



Flip the assembly over and secure the keyboard bezel to the top cover with 6 screws (Item 20).

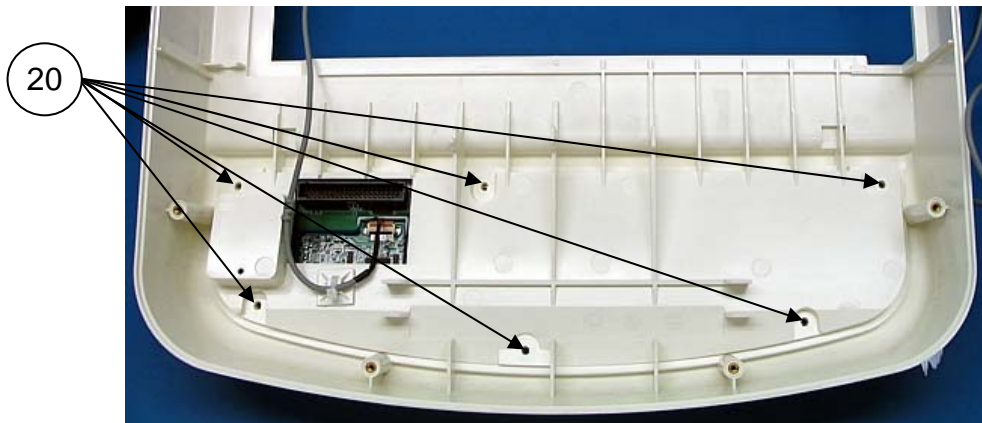

Retain USB cable to Top Housing using (part of the core BOM) using Cable Tie (Item 25) and Cable Tie Mount (Item 29).



### MODEM OPTION

ATTENTION: Solder all components to the motherboard prior to installing the motherboard into the base assembly.

Solder MODEM module and components to the motherboard. The module should be seated so that components from the module contact the motherboard.

Item 1A – Common Mode Choke

Item 2A – Modem Connector

Item 3A – Poly fuse

Item 6A – Modem Module

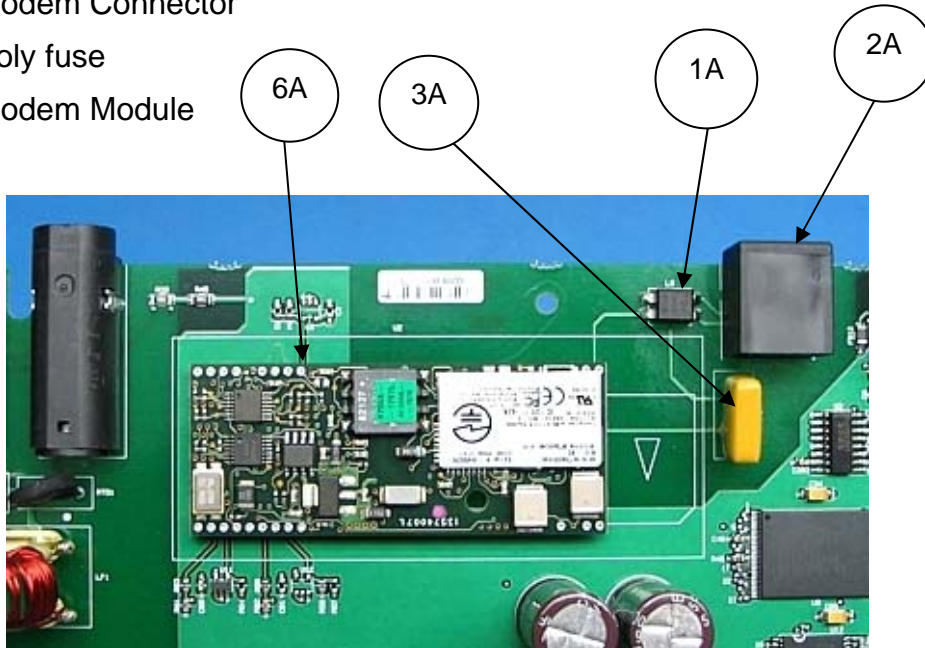

Place the FCC Label onto Bottom Housing as shown.



## WLAN Option

**Note:** The ELI350 was produced with either a WLAN-B module or a WLAN-G module. Refer to the first 4 letters of the item number to identify the module type installed (example = MLANB- would indicate a “B” module)

**ATTENTION:** Solder all components to the motherboard prior to installing the motherboard into the base assembly.

Solder WLAN module to the motherboard. The module should be seated so that components from the module contact the motherboard.

(Item 4A) – DPAC Module



### WLAN B CONNECTION

Press the coax cable (Item 5A) into the DPAC WLAN module connector J1 as shown until the cable is fully engaged as indicated by a click.

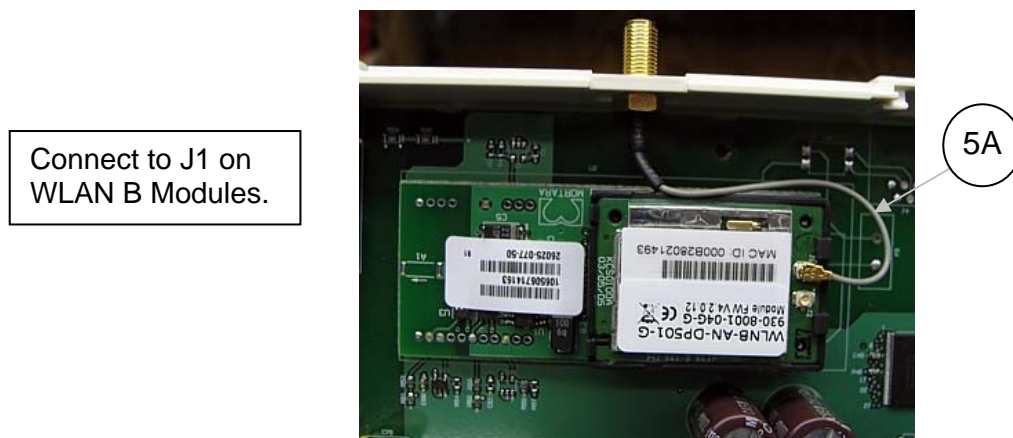

### WLAN G CONNECTION

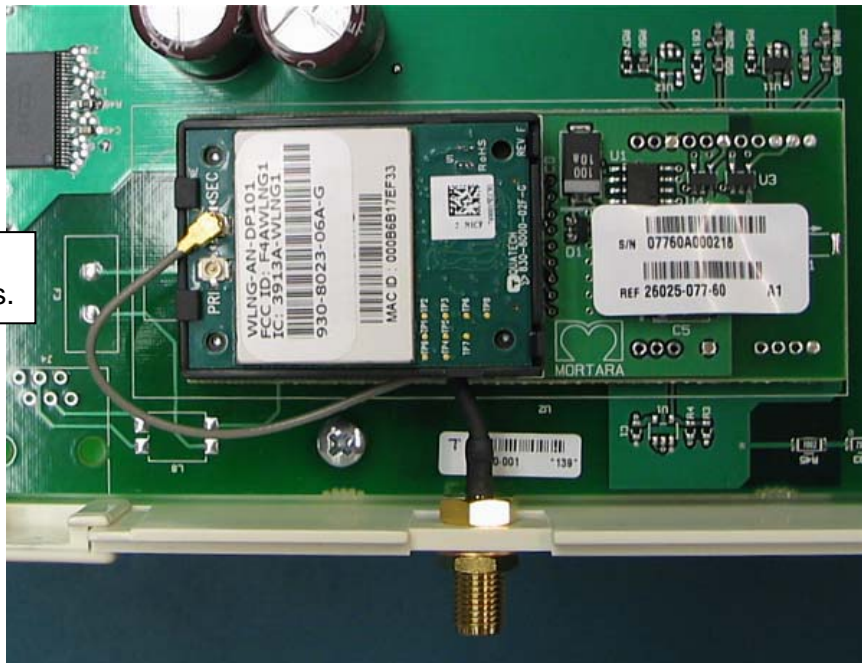

Press the Coax Cable (Item 5A) into the DPAC WLAN module connector J2(SEC) as shown until the cable is fully engaged as indicated by a click.

Install antenna connector (part of Item 5A) through the rear I/O panel and secure using the hardware provided with the connector

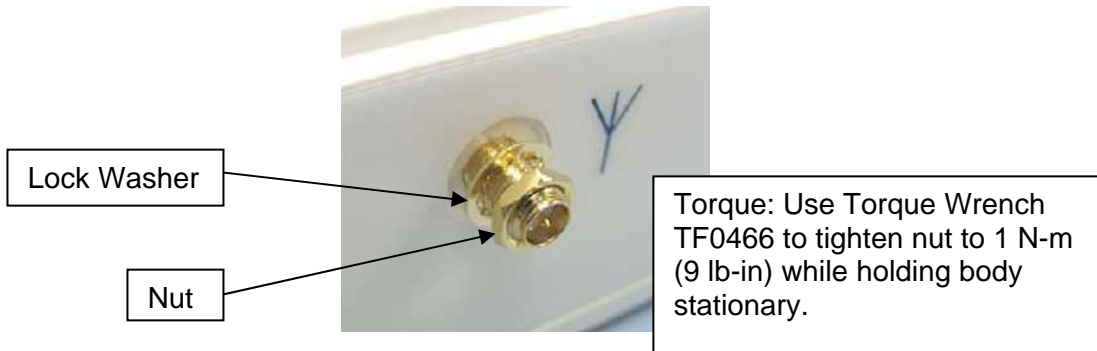

ELI350 Option Items		
Sequence #	Item Number	Item Description
1A	600-0515	COMMON MODE CHOKE 2A 4 PIN SM
2A	3225-003	CONN, MOD PHONE, 4 PIN, RA, LO PRO
3A	4027-001	FUSE POLYSWITCH TR 600V 150mA
4A	26025-077-60	DPAC-G WLAN MODULE PCB ASSEMBLY
5A	3171-010	CABLE COAX U.FL TO RP-SMA BLKHD 100mm
6A	9910-017	MODEM MULTITECH MT5600 V.92 5V SERIAL



### ***ELI 350 Upper Level Assembly***

Note: Item numbers in this section refer to the parts on the core assembly BOM. Blanking covers are required to plug all unused openings. The blanking covers are part of the option kit BOM's. Installation of the square blank cover and round blank cover will depend on the install Communication Options.

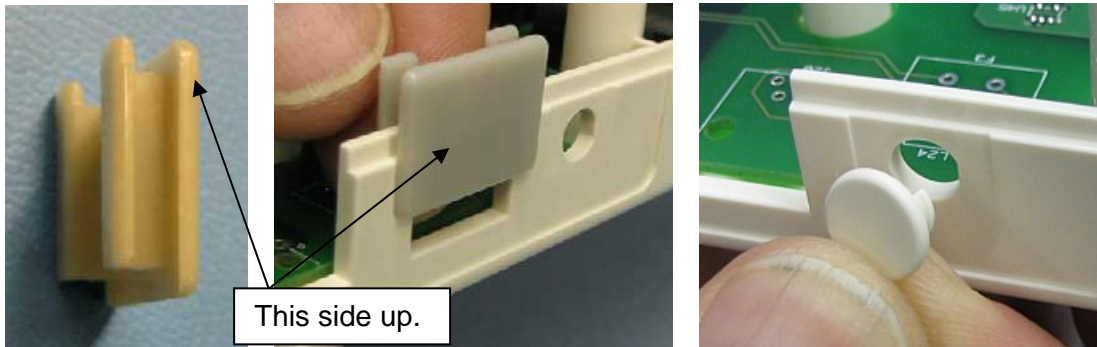

COMMS Options: None, Serial, LAN

Hardware for the Serial Option and LAN Option are standard on all units.  
*(fuse ratings pictured below are from a unit with display # 5400-016)*



COMMS Option: Modem

*(fuse ratings pictured below are from a unit with display # 5400-016)*



COMMS Option: WLAN

Note: Ensure the proper antenna is applied.

*(fuse ratings pictured below are from a unit with display # 5400-016)*



Antenna shown here connected for test purpose only. Disconnect the antenna to ship along with the unit.

*(fuse ratings pictured below are from a unit with display # 5400-016)*



Place the LCD Display Sub-assembly (Item 8) on the Lower Housing as shown.

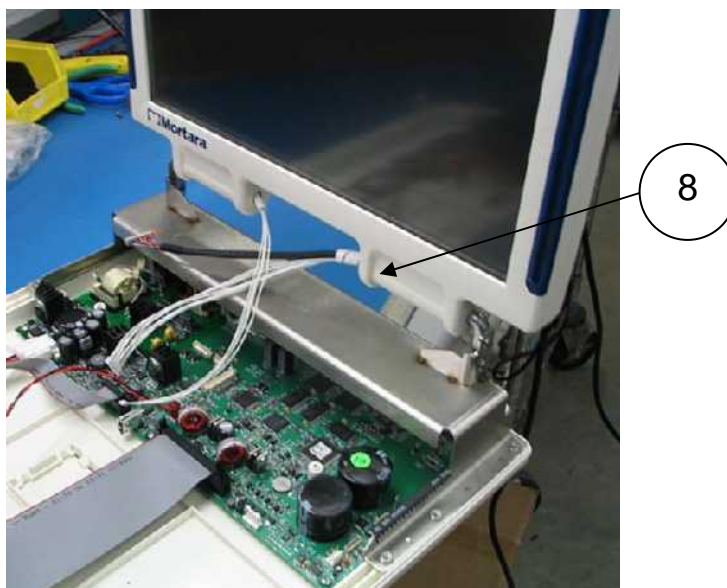

Secure the LCD Display assembly (Item 8, Ref) to the Lower Housing using 4 screws with Vibra-Tite (Item 31) in the locations marked with the display mount symbol.

Note: 2 locations are circled for reference only. DO NOT use the location marked with an X (REF: Location used to mount ELI 350 to Cart).

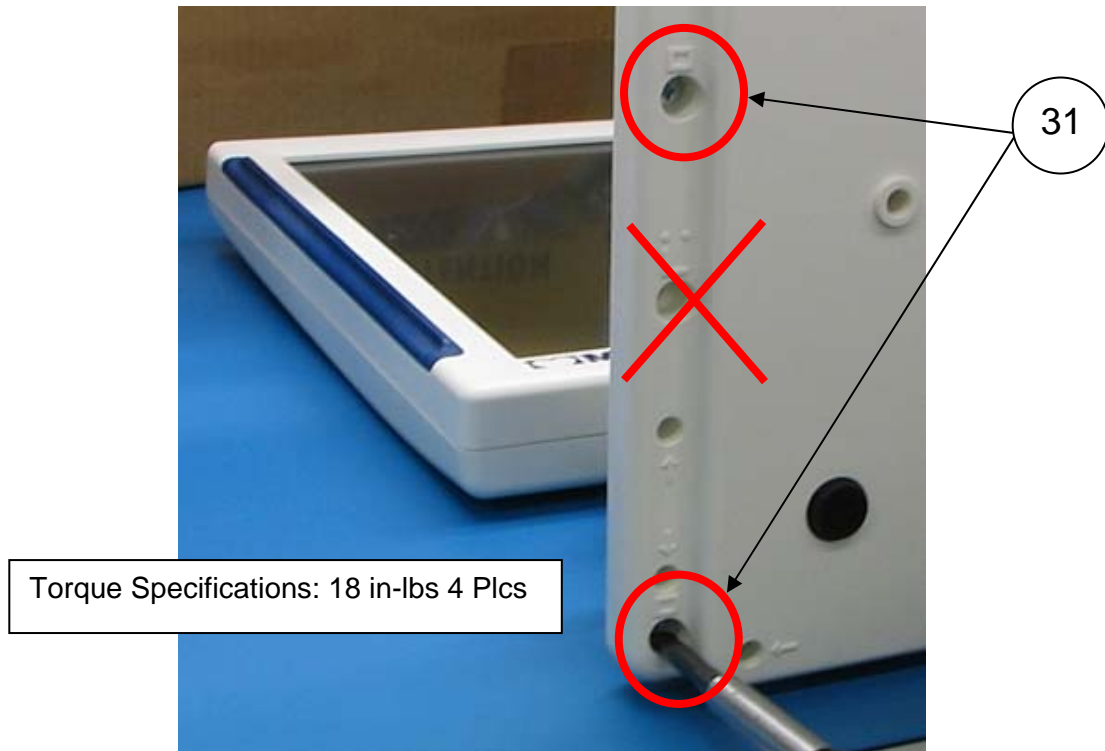

Connect LCD display cables (Qty 3) to the Motherboard as shown. Ensure cables are fully seated

Note: All cables are keyed

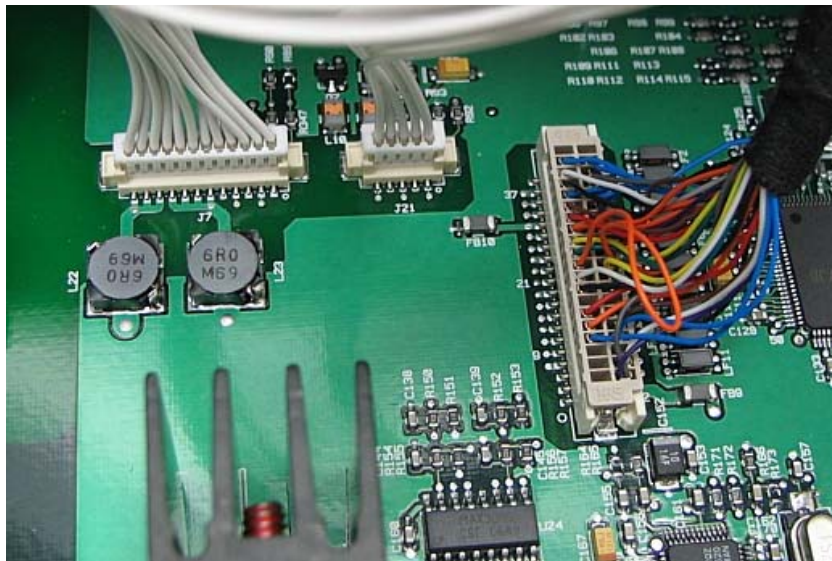

Tie-wrap (Item 25) the LCD display cables as shown to prevent them from getting pinched later in the hinge and rear cover housings. Cut the excess length from the tie-wrap.



Install Writer Assembly (Item 10) – DO NOT rest the Writer Assembly directly on the motherboard.



Connect the writer cue sensor to J15 and the stepper motor to J18 on the motherboard.

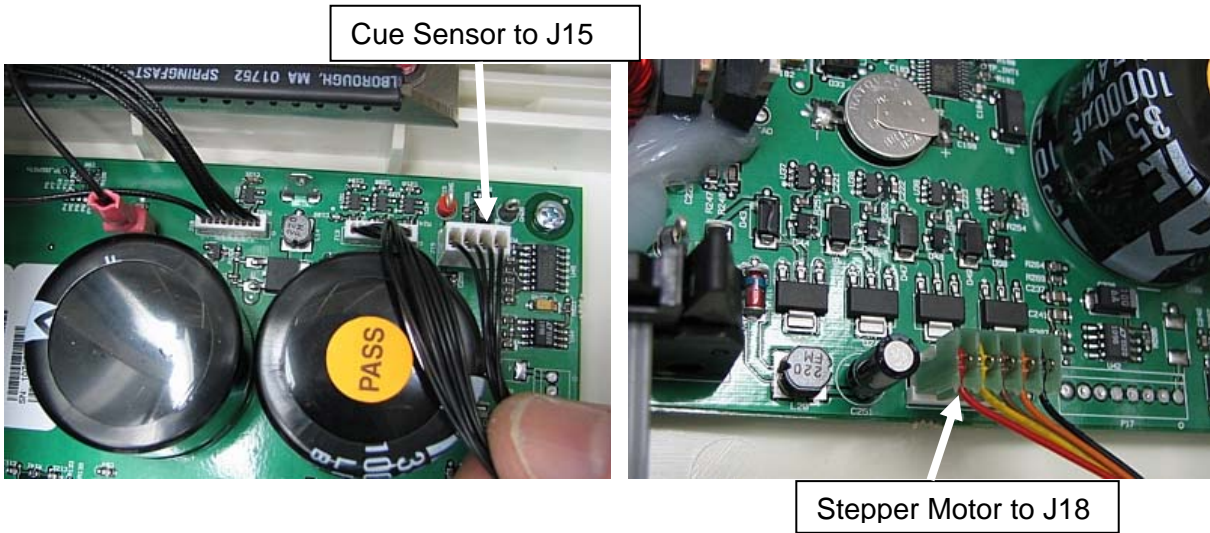

Connect the writer print head cables to the motherboard (longer cable to J13; shorter cable to J10).

Connect the writer static ground wire from the writer to Gnd2 on the motherboard the motherboard.

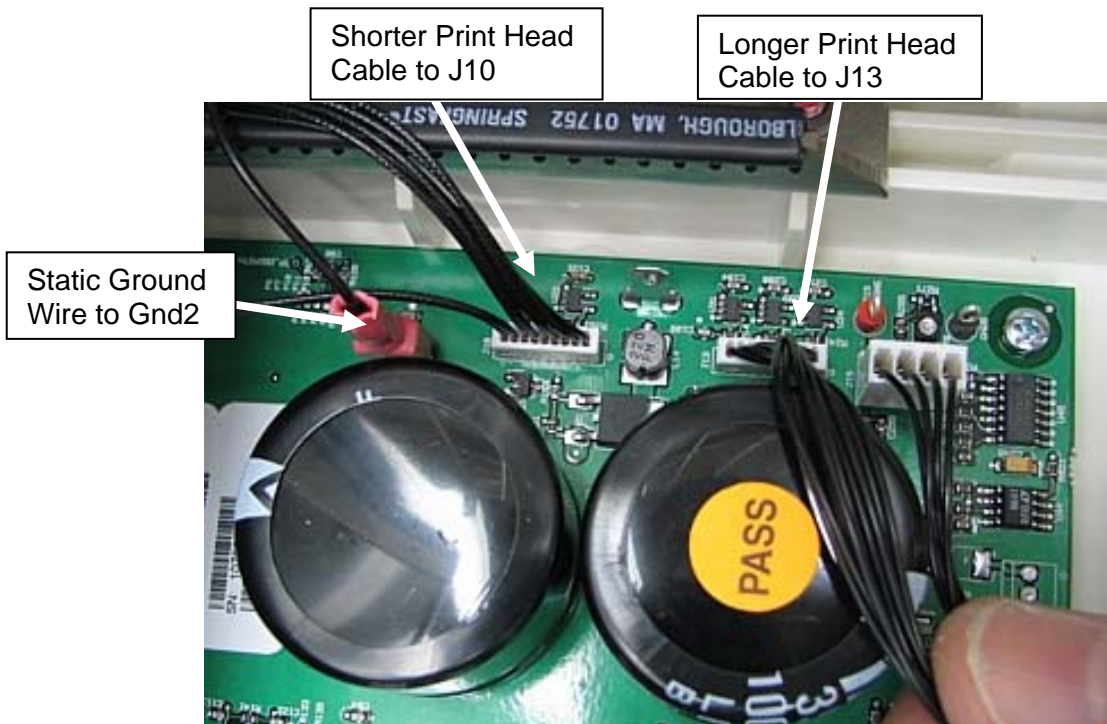

Connect a keyboard assembly to the base assembly and apply AC power to the base

**CAUTION: Risk of Shock** – Line voltage may be present on the Motherboard. DO NOT touch components on the motherboard when performing confidence testing at the sub-assembly level.

Insert a pack of paper (Standard or A4 as applicable) into the writer tray and close the writer drawer.

Manually pull the paper so that it is positioned midway through the page allowing the cue sensor to be located over white space on the paper.

Connect a volt meter set on the 20 VDC scale to the RED (P15) and BLACK (GND5) of the motherboard. Adjust R270 until the meter reads 2.00 VDC

CRITERIA: Cue Sensor Settings: 2.0 VDC (Acceptable Range 1.90 – 2.10 VDC)

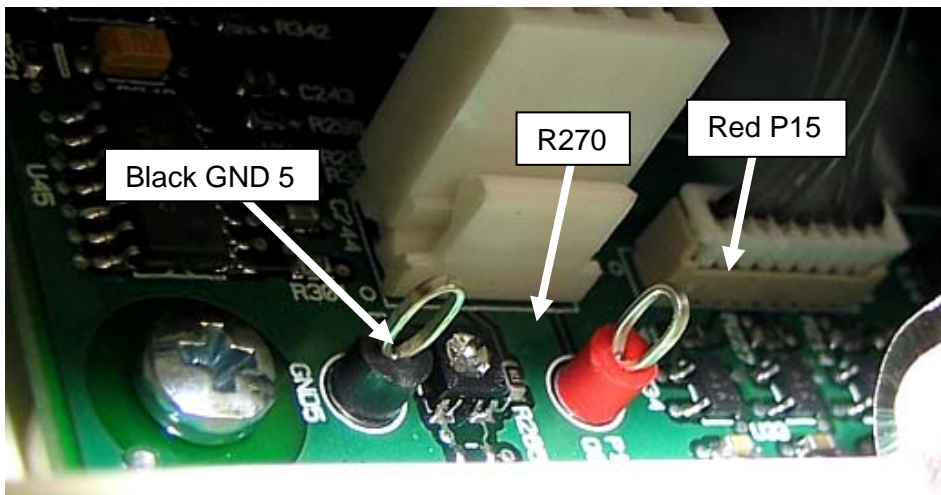

Manually pull the paper until the cue mark of the paper is directly over the cue sensor.

CRITERIA: Ensure the meter readings is less than 0.5 VDC

Position the writer on the lower housing 4 mounting standoffs. Secure the writer to the lower housing using 4 screws (Item 21)



Retain both the print head and cue sensor cables in the clip as shown. Use caution so that the cables are not disconnected.

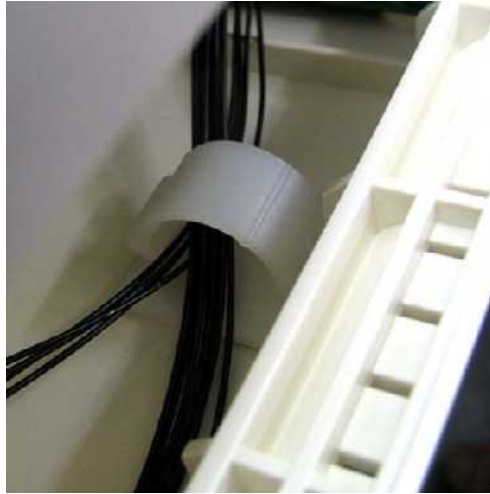

Tilt the LCD Monitor down to install the Rear Housing (Item 5).



Close the LCD display in order to insert the Rear Housing to the Lower Housing. Mount the Rear Housing to the base assembly using 3 screws (Item 21)

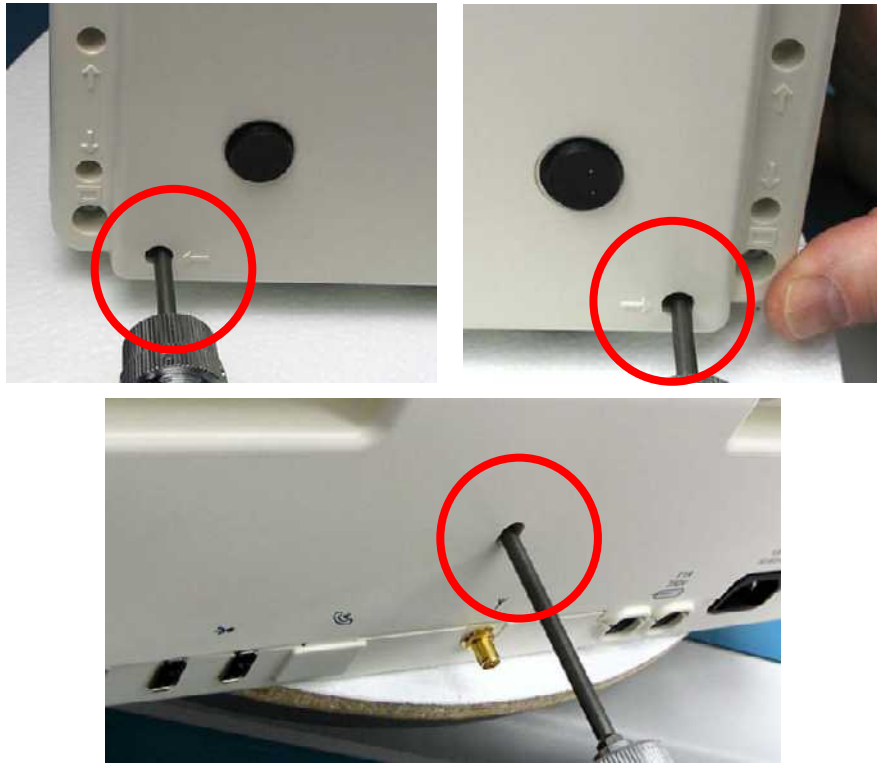

Insert silicon plug (Item 7) into the Rear Housing location. Note: The Arrow on the silicon plug must be UP.

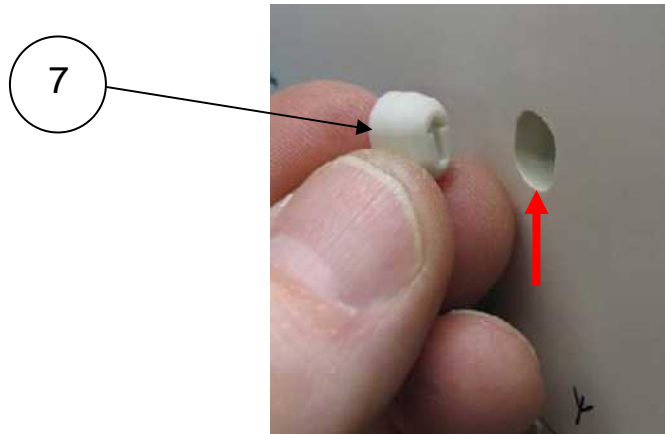



Open the LCD Monitor to assemble the Hinge Cover Housing (Item 4) to the Base Assembly.



Secure the Hinge Cover Housing to the Lower Housing using 2 screws (Item 21).

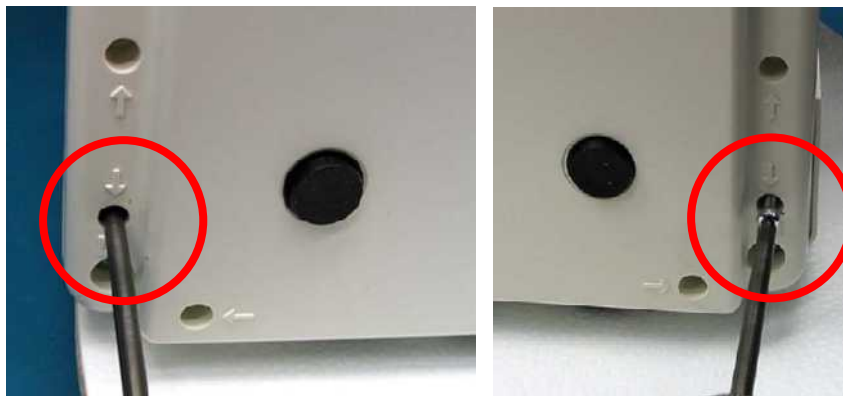

SNAP the Hinge Cover Housing to the Rear Housing. Ensure the LCD Monitor cables are not pinched between the housings.



Assemble the applicable (Click Knob or Touch Pad) Top Cover Assembly as shown.  
Click Knob Top Cover Assembly shown for Reference Only.



Required for both Click Knob and Touch Pad Top Cover Assemblies.  
Connect the Keyboard Ribbon Cable to the underside of the Top Cover Assembly.



Required for Touch Pad Top Cover Assembly only.

Connect the Touch Pad cable to the USB connection of the motherboard J20 located under the writer.

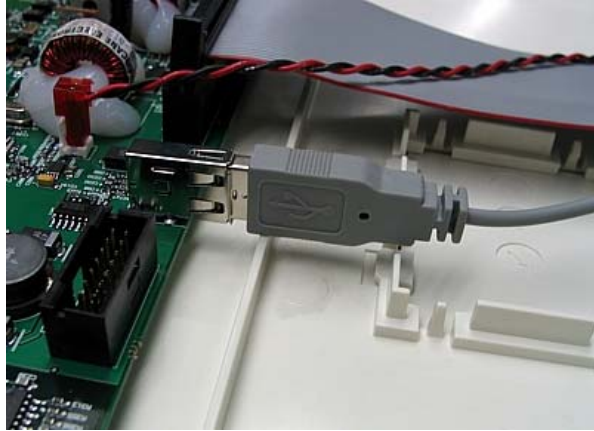

Also, retain extra cable length using C-Clip (Item 26)

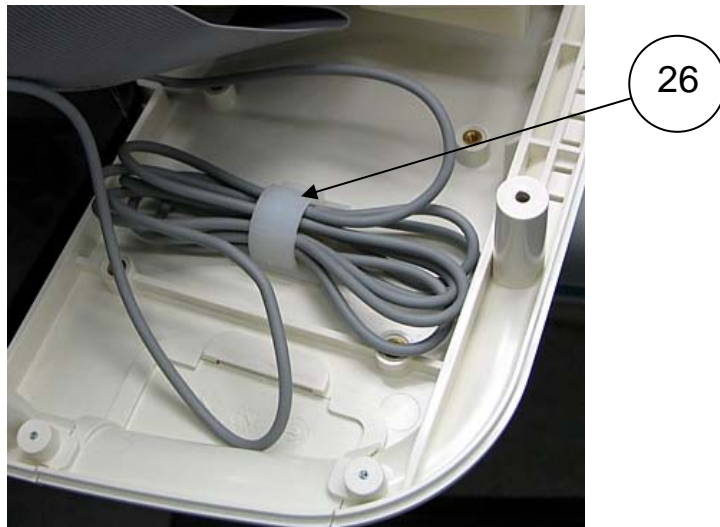

Seat the Top Cover Assembly to the Lower Housing Assembly and secure with 7 screws (Item 21) M3 X 10

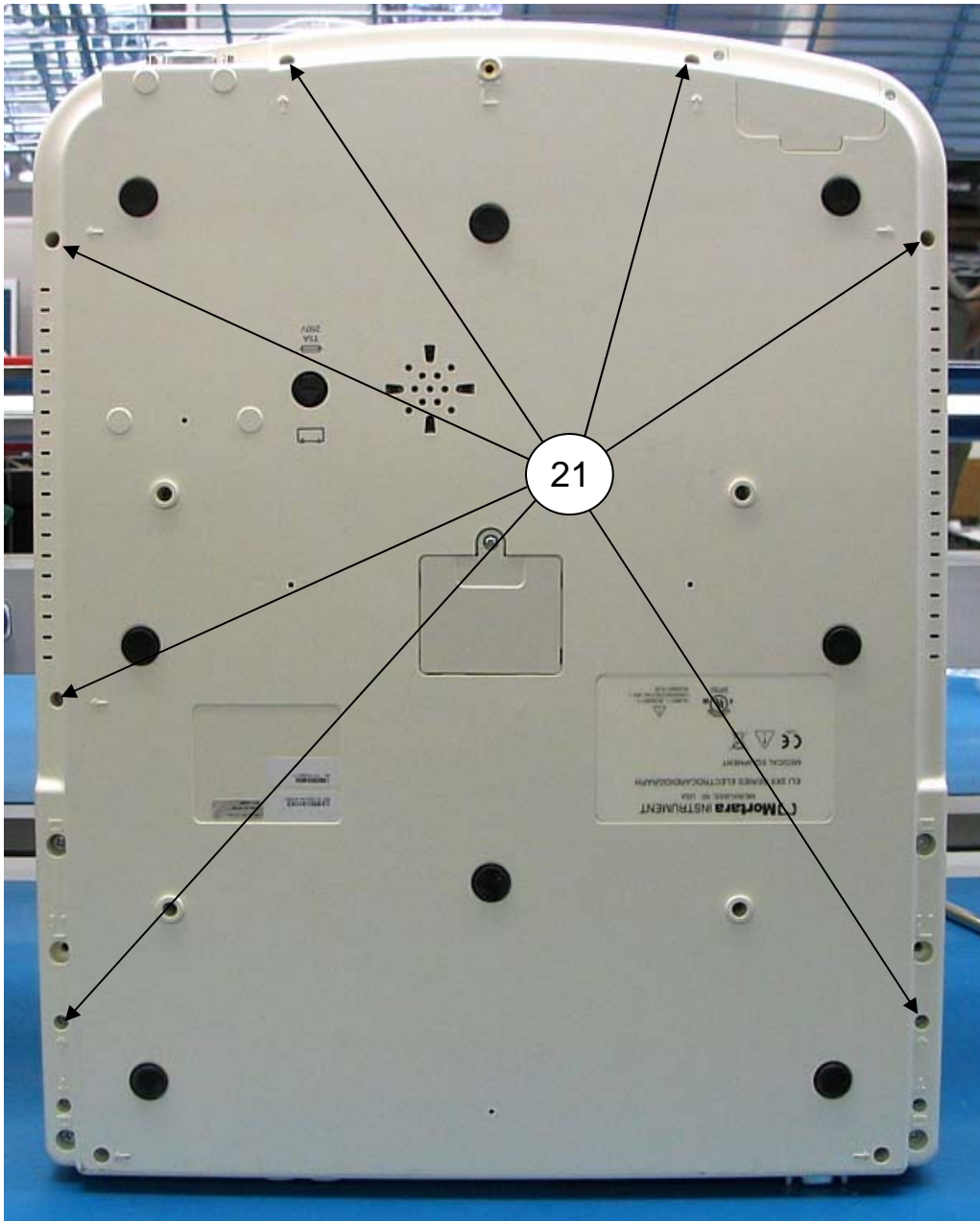

## ELI 350 Labeling and Cosmetic Items

Note: The parts in this section refer to the parts defined in the configuration of this unit. Item numbers are not used. A description and picture will be used to identify the part.

This section defines the location(s) and type(s) of labels required.

- Verify or applied as needed

### *Bottom of the Assembly*

Apply the following labels:

- Product Label (Item 28) in the recessed area provided and in the orientation shown.
- Windows CE License
- Serial Number
- Reference Number
- If Communications Options - Applicable Modem Label
- Inmetro label is required for Brazilian units

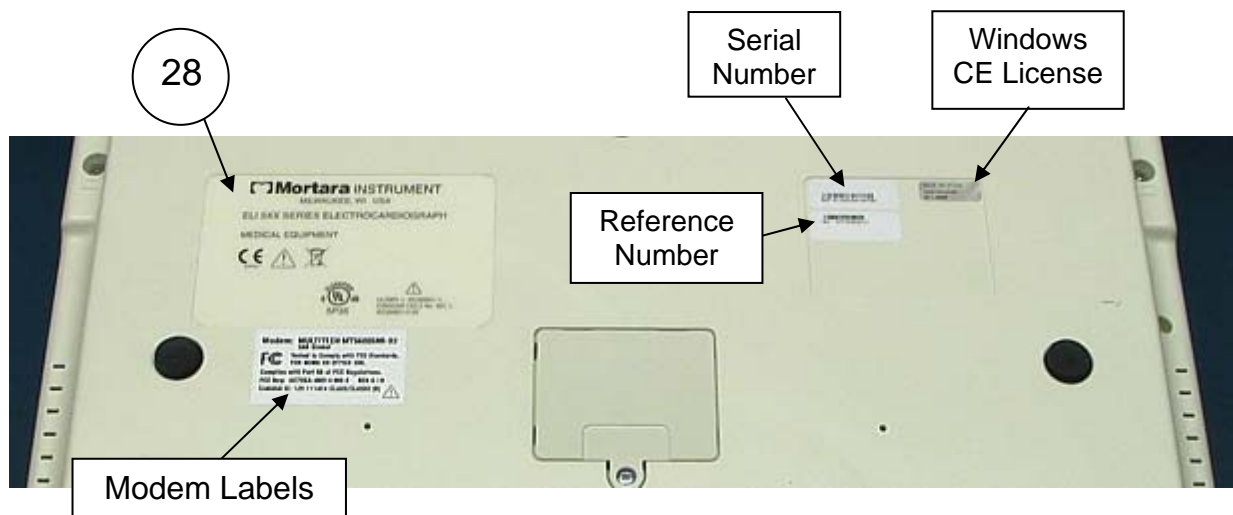

Rear of the Assembly



Silicone Inserts

Silk Screening  
LCD Display

Light Sensor  
Label



Silicone  
Inserts

Mortara Logo



Silicon Inserts 2 plcs on rear of LCD display

*Keyboard*

Verify the applicable Battery / Power Label has been applied to the keyboard assembly

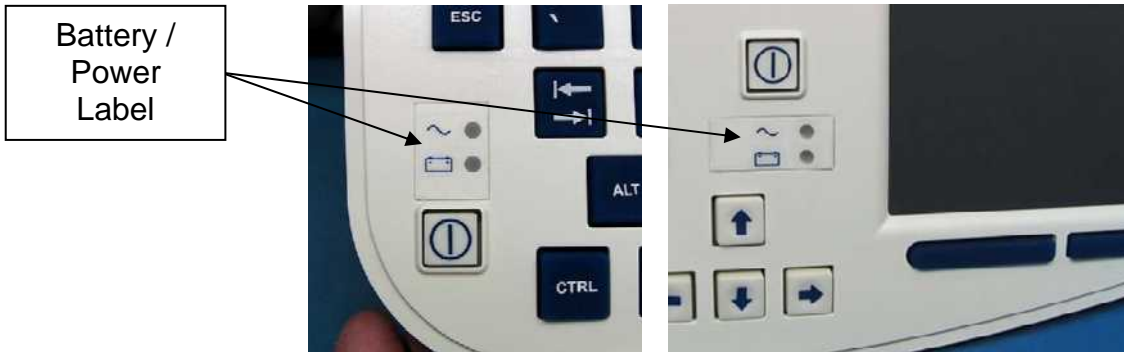

*Writer*

Install User Instructions Label onto Core Assembly as shown. Place label in recessed area on paper cover. The User Instructions Label should be placed against left edge of recessed area as shown.

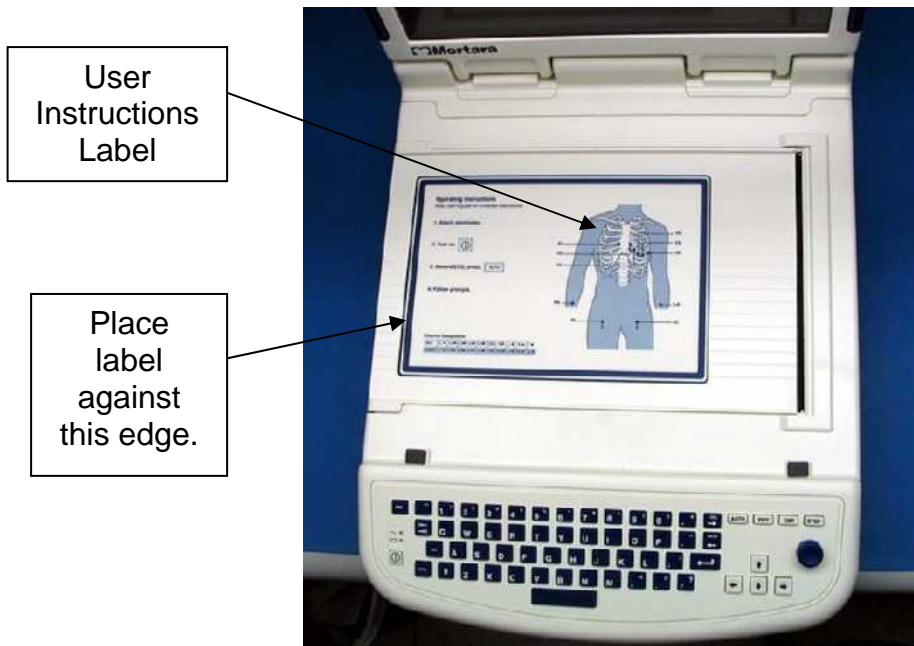

If A4 Spacer is part of configuration, install A4 Spacer into Paper Tray as shown. Snap into place.

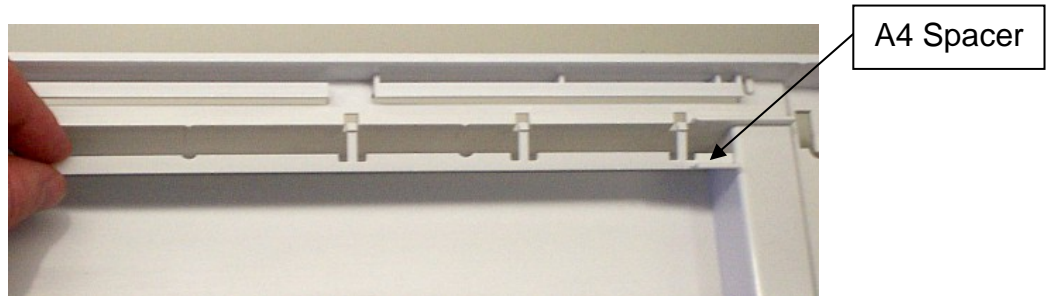

ELI350 Core Assembly		
Sequence #	Item Number	Item Description
1	4800-010	BATTERY RECHARGEABLE SLA 12V 9Ah
2	8351-001-50	HOUSING UPPER ELI 350
3	8351-002-50	HOUSING LOWER ELI 350
4	8351-003-50	HOUSING HINGE COVER ELI 350
5	8351-004-50	HOUSING REAR COVER ELI 350
6	8351-008-50	BULKHEAD ELI 350 FRONT CLOSURE PANEL
7	8351-023-50	PLUG ELASTOMERIC REAR COVER ELI 350
8	8351-024-50	LCD MONITOR ASSEMBLY ELI 350
9	8351-029-50	LCD BUMPER ELI 350
10	22500-200-61	WRITER ASSEMBLY ELI 350
11	25018-039-50	CABLE ASSEMBLY ELI 350 FRONT END
12	25020-053-52	SPEAKER LEADS & CONN ASSY ELI 350
13	25020-063-50	CABLE ASSY BATTERY TO PCB ELI 150
14	26025-043-51	10K+ FRONT END PCB ASSY
14a	26025-044-51	10K+ AUXILIARY PCB ASSY
15	26025-076-51	ELI 350 MOTHERBOARD PCB ASSEMBLY
	26025-076-52	ELI 350 MOTHERBOARD PCB ASSEMBLY (layout #2 - FPGA)
	26025-076-53	ELI 350 MOTHERBOARD PCB ASSEMBLY (layout #3)
16	4021-006	FUSE 5 AMP TYPE T SLO BLO 250V
17	4110-006	FUSE HOLDER 5 X 20 PANEL SNAP-IN MT SLTD
18	6020-430-02	SCREW PHILLIPS PAN HEAD M3 X 6mm COATED
19	6020-530	SCREW PHILLIPS PANHEAD M3 x 5 ZINC PLTD
20	6020-831	SCREW PHILLIPS PANHD M3X8 ZINC PLTD
21	6020-930	SCREW PHILLIPS PANHEAD M3 x 10 ZINC PLTD
22	6320-003	FOOT BLACK .64 OD X .115 ADHESIVE
23	7401-003	TAPE 2SIDED ADHESIVE 0.031 THK x.50 WIDE
24	7403-001	VIBRA-TITE 1oz
25	7495-001	CABLE TIE LOCKING 3.9 x .10
26	7500-008	CLIP WIRE CORD 1x1x.53ID WHITE W/ADHESIV
27	8347-007-50	ACCESS COVER ELI 150
28	9042-063-01	LABEL ELI 3XX SERIES NAMEPLATE
29	7495-008	MOUNT CABLE TIE ADHESIVE BACKER .75 X.75
30	6020-050	SCREW THD-FORM PAN HD TORX M2.5 X 10mm
31	6020-006-02	SCREW M4x0.7x8mm PHILLIPS PAN HD COATED
32	4021-006	FUSE 8A 250V TYPE T 5 X 20mm
33	4021-006	FUSE TYPE T 250V 1A 5 x 20MM SLO
34	4021-006	FUSE, TYPE T, 250V, 2A, 5 x 20mm, SLO
35	9042-068-01	LABEL FUSE RATING SET – ELI350
36	25018-040-50	CABLE ASSY ELI 350 KEYBOARD TO MOTHERBD
37	26025-080-50	ELI 350 KEYBOARD w/TRIM KNOB PCB ASSY
38	8351-016-50	ELASTOMERIC KEYPAD WO TOUCHPAD ELI350
39	8351-006-50	BEZEL KEYPAD WITHOUT TP ELI 350
40	9042-056-02	LABEL AC ON/BATTERY CHARGED ELI 350 w/TK
41	8351-017-50	KNOB TRIM ELI 350



### **LCD Electronic Assembly**

Remove the protective plastic from the front of the LCD (Item 2). Viewing the LCD from the front, note the side marked "UP".

Use caution throughout this procedure to minimize finger contact with the front of the display. The protective plastic will be used during the assembly of the LCD for this purpose.

Place the U-Shape mounting bracket (Item 11) over the LCD (Ref: Item 2) as shown. Replace the protective plastic on top of the LCD using the supplied tape to retain the plastic to the LCD.

Starting at the top, fasten the U-Shape bracket to the LCD using (Item 14, 4 Plcs.) shoulder screws with Vibra-Tite.

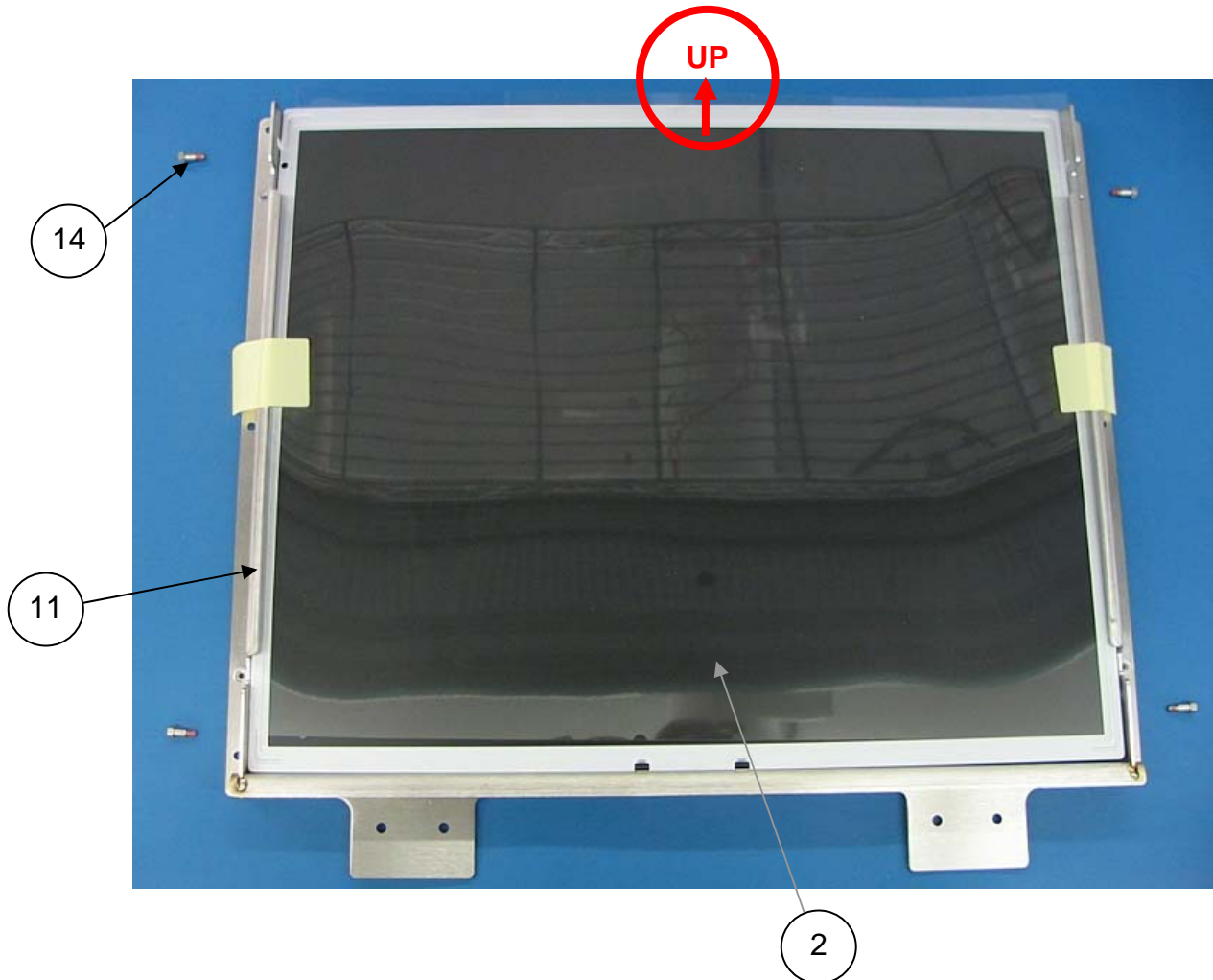

Flip the assembly over to mark the cable routings and backlight PCB location. Use caution not to damage the front of the LCD.

Place the cable marking assembly aid in the U-bracket holes. Using a fine point marker, trace a line in each of the openings.

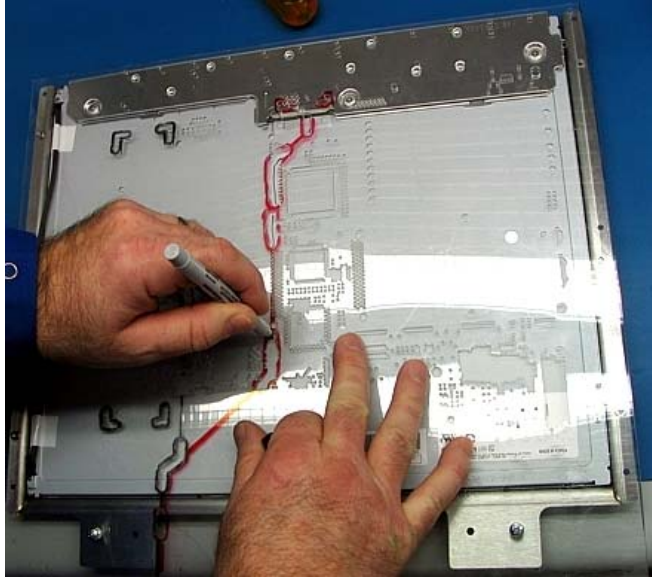

Cut 2 pieces of double sided foam tape (Item 35) approximately 6.5 to 7.0" in length and apply the tape to the backside of the Backlight Inverter Module PCB (Item 9) as shown.

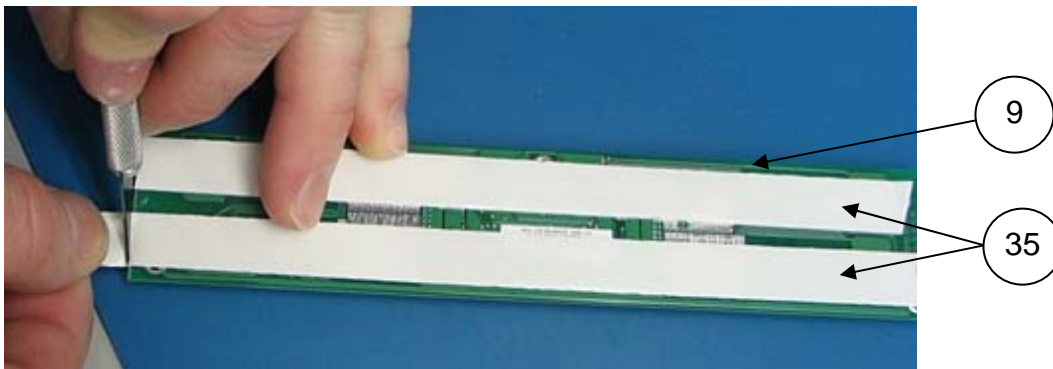

Ensure the tape covers each of the 4 High Voltage spark-gap holes located between the connectors and coils. (Top side view)

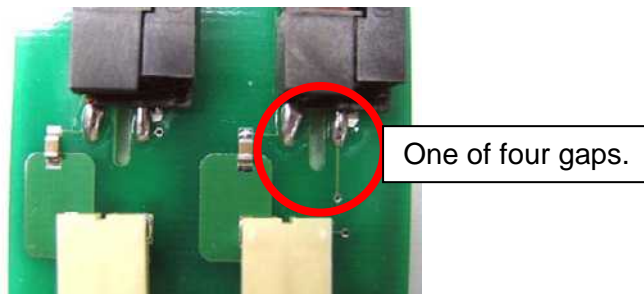

Remove the backing from the double sided tape and mount the Backlight Inverter Module PCB to the LCD centering within markings

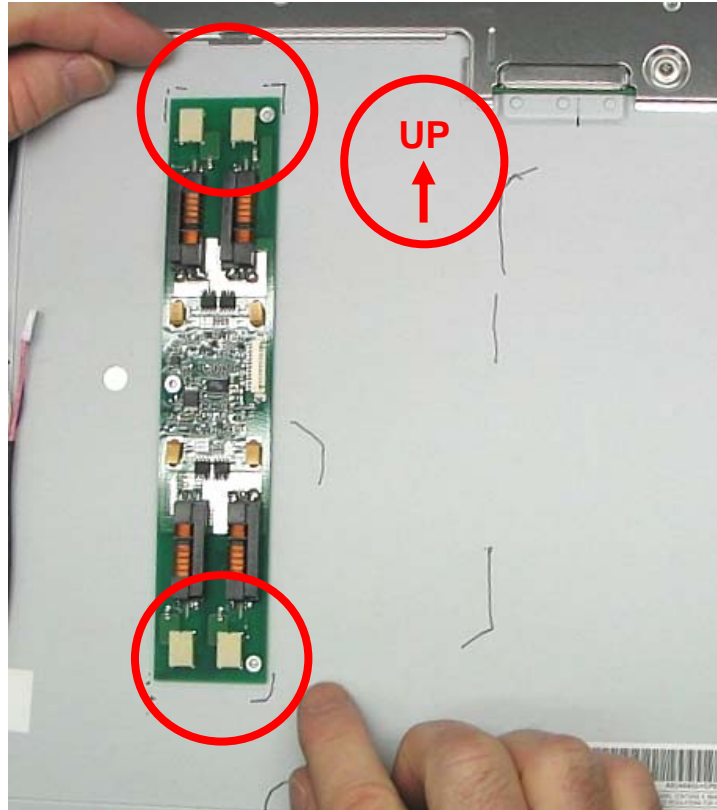

Plug the Inverted cable connectors from the LCD to the Backlight Inverter Module PCB as shown (4 Plcs).

NOTE: Functionally it does NOT matter which cable is connected to which connector.  
For consistency however, connect the colored cables to the left connector.

Place a piece of tape (Item 29) to retain each of the cables in place as shown (2 Plcs.)

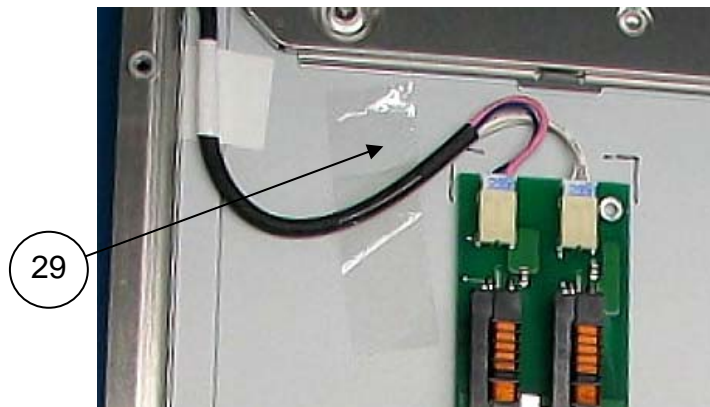

Insert the Backlight Inverter cable (Item 21) to the PCB Assembly. Route the cable as shown using the markings created on the LCD and retain the cable to the LCD with a piece of tape (Item 29)

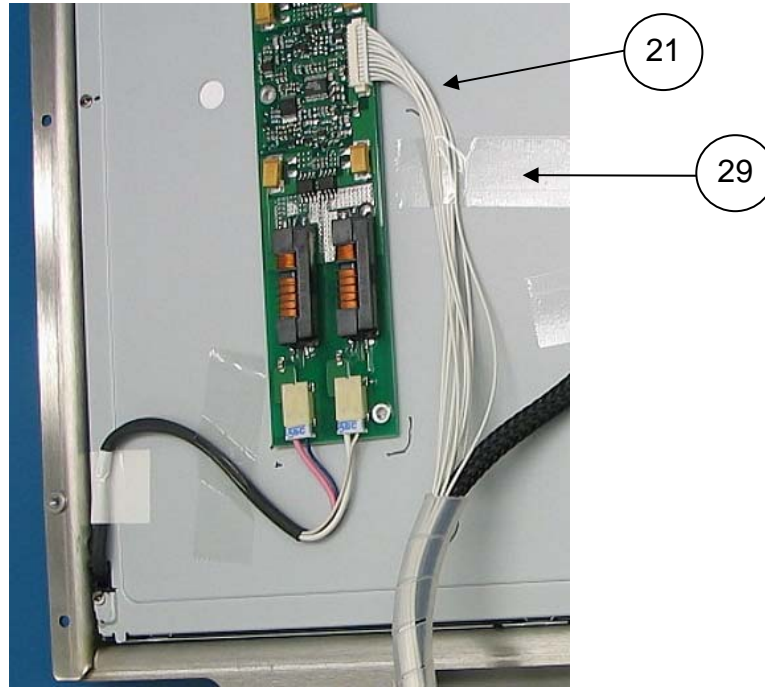

Insert and fully seat the LCD signal cable (Item 20) to the LCD.

Note: The conductor pins are face up viewable by the operator

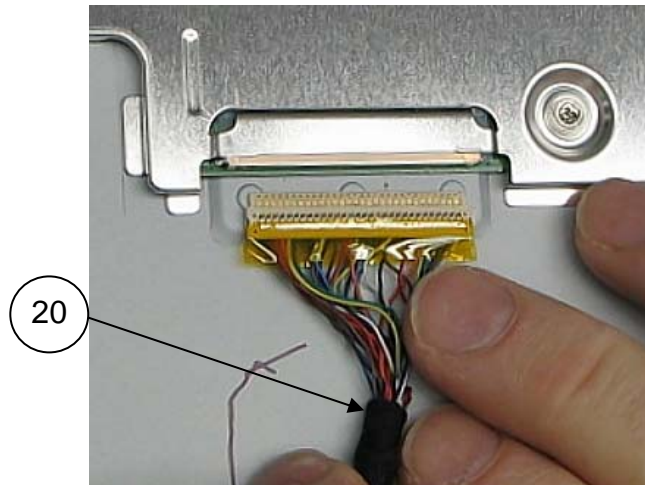

Route the cable as shown using the markings created on the LCD. Retain the cable to the LCD with a piece of tape (Item 29)

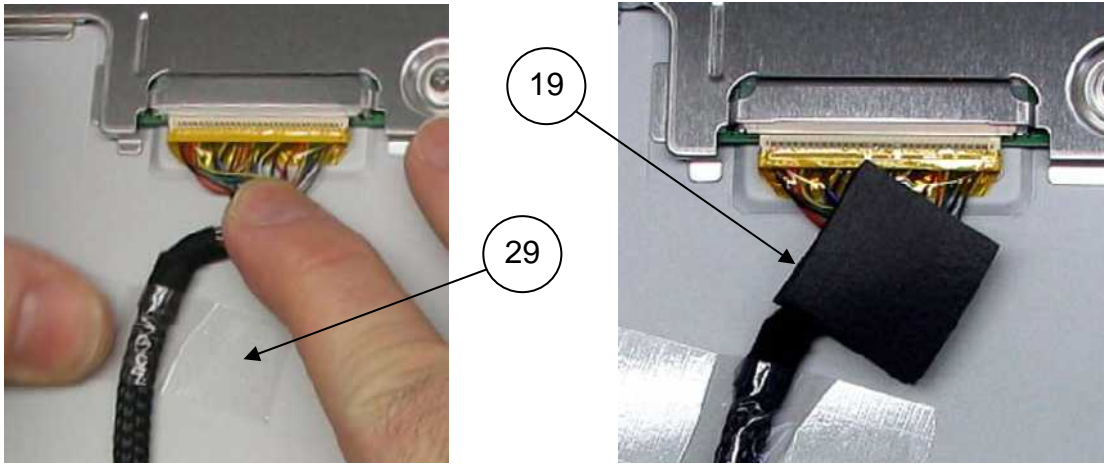

Apply LCD support block foam (Item 19) to retain signal cable top to the LCD.

NOTE: Do NOT place the block foam directly over the connector

Route the cable (REF: Item 20) as shown using the markings created on the LCD. Retain the cable to the LCD with a piece of tape as shown (Item 29)

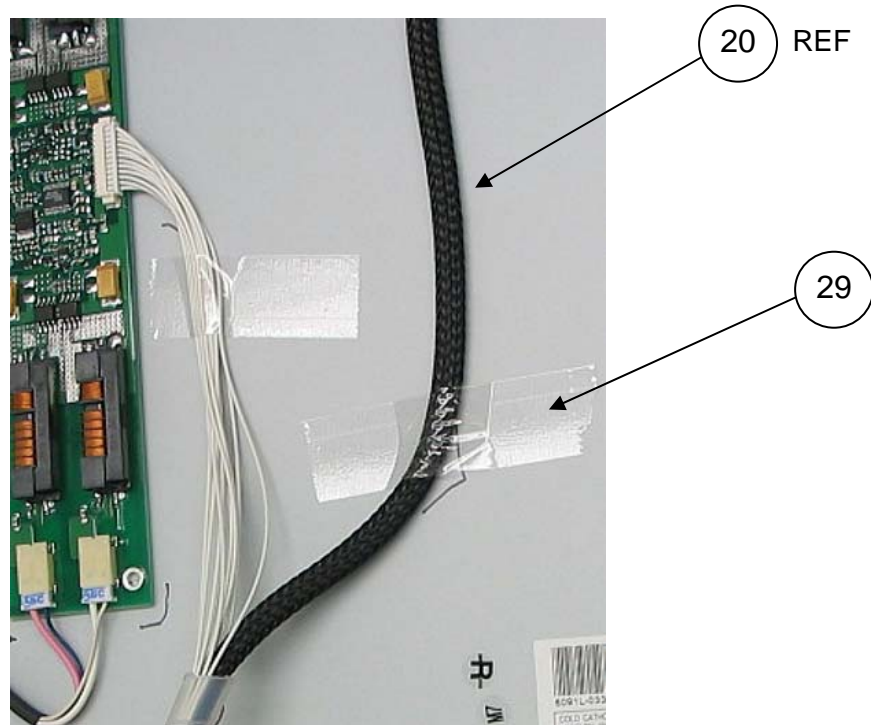

Cut a piece of 3/8" spiral wrap (Item 32) 4 inches long. Capture both the LCD Backlight cable and LCD Signal Cable within the spiral wrap as shown.

NOTE: The spiral wrap is used to ensure the cables will not be compromised by any sharp edges.

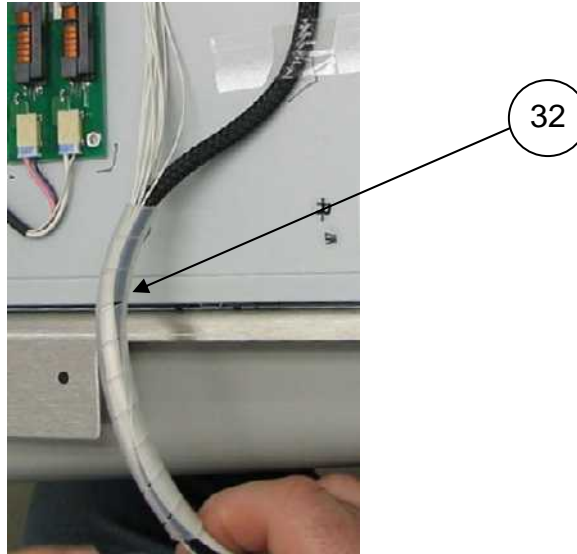

### **LCD Rear Housing Assembly**

Trim all through hole component leads flush to the Tilt Switch PCB Assembly (Item 23) as shown.

Also, ensure the corners (2 Plcs) of the PCB assembly have the break out tabs trimmed flush to the corner of the PCB assembly.

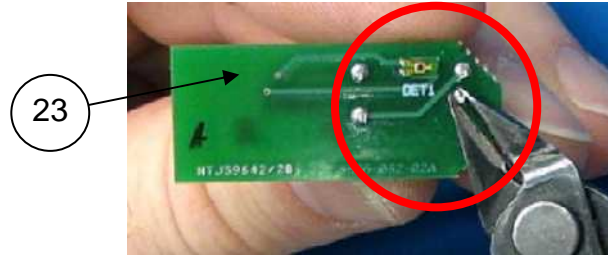

Connect the Tilt Switch cable (Item 22) to the Tilt Switch PCB Assembly (REF: Item 23) and insert the PCB into the display Rear Housing (Item 1) as shown.

Press on the PCB assembly to ensure it is fully seated into the rear housing.

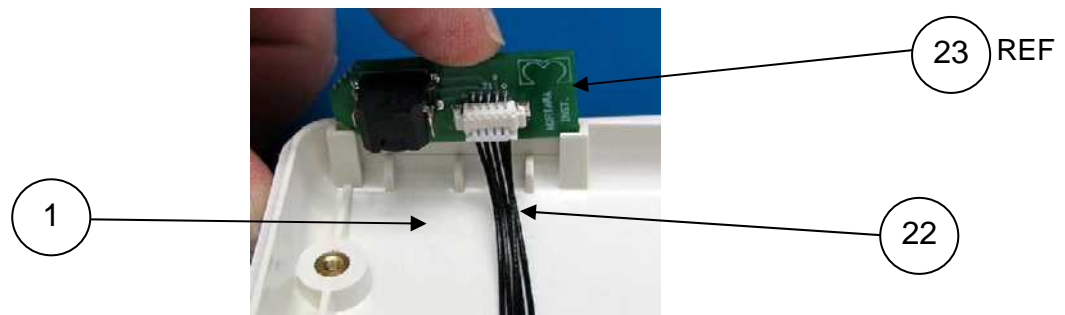

Route the tilt switch cable as shown using the rear housing as a guide. Retain the cable to the rear housing with tape (Item 29) 2 Plcs typical.

Install Qty 6 LCD support blocks (Item 19) as shown. Double stack the bottom 2 blocks.

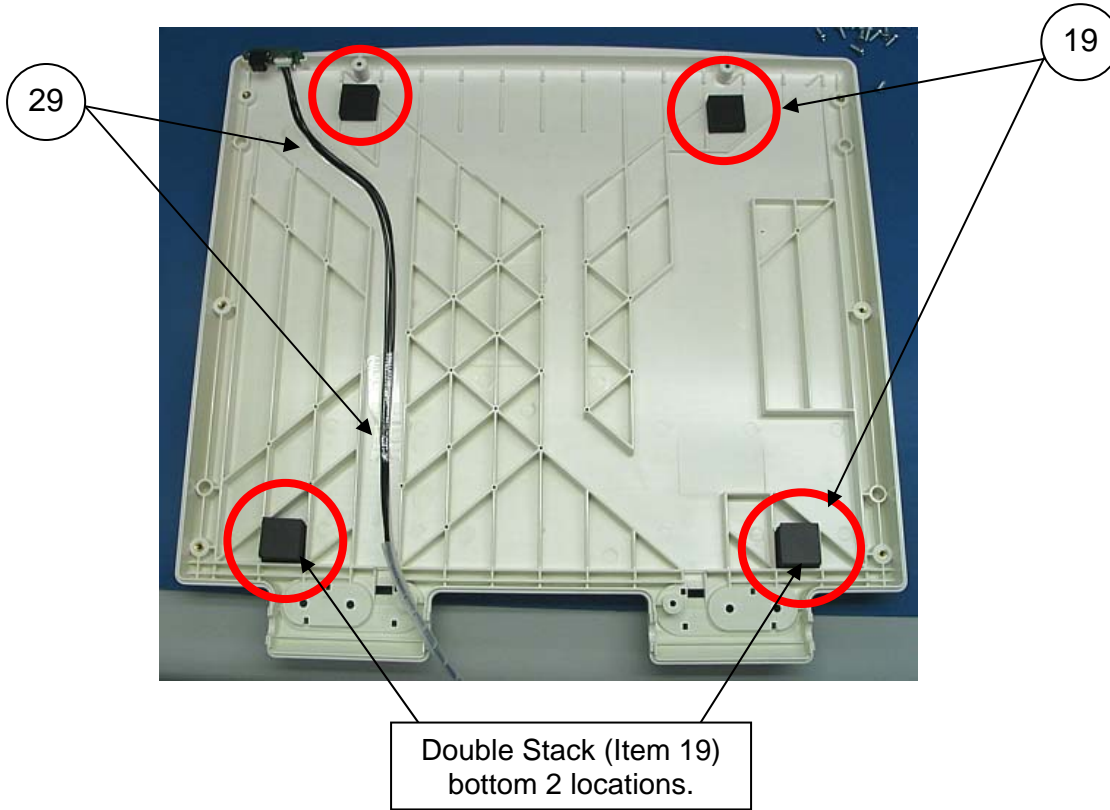

Cut a piece of 1/4" spiral wrap (Item 31) approximately 4" in length and apply to tilt cable as shown. The spiral wrap will be routed through the rear housing hinge area as shown

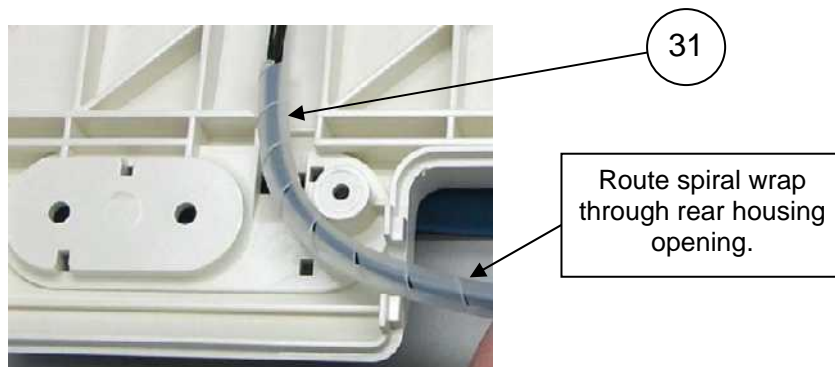



Flip LCD electronic assembly over and place into the back housing as shown

**Caution:** Route the cables to prevent any pinch points.

**Caution:** Prevent contact with the LCD surface. The protective plastic sheet may be used.

Fasten the LCD electronic assembly to the Rear Housing using 6 screws (Item 28) as shown. Ref: As a guide start the 2 screws closest to the hinge mounts first.

**NOTE:** There are also 4 mounting holes with threaded inserts used to fasten the Front Housing to the Rear Housing. Ensure these holes are NOT used.

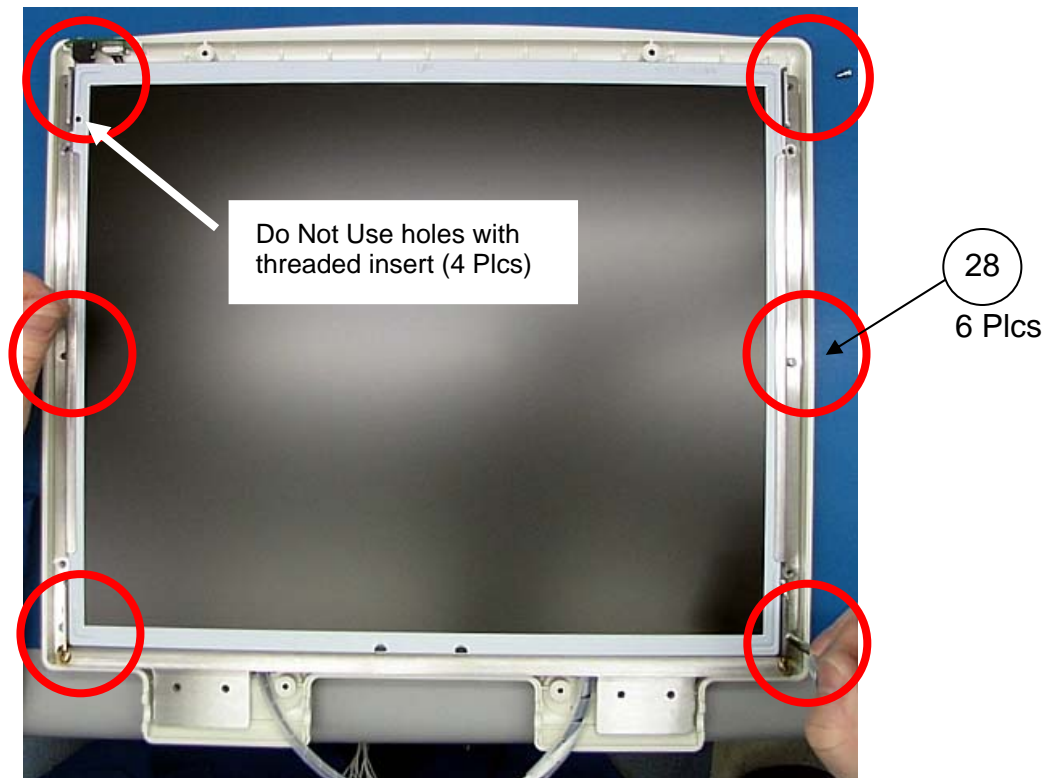

Apply adhesive backed lens support foam (Item 18, 2 Plcs) to TOP and BOTTOM of LCD metal frame (bottom only is shown).

Ensure foam tape does not interfere with the U-bracket so that the display can float.

Ensure foam tape does not contact the LCD surface.



### Hinge Assembly

Apply Vibra-Tite (Item 30) to 4 Screws (Item 33). Assemble hinges (Item 24 & Item 25) to the Bracket Assembly LC Hinge (Item 10) noting the orientation of the hinges (Left & Right).

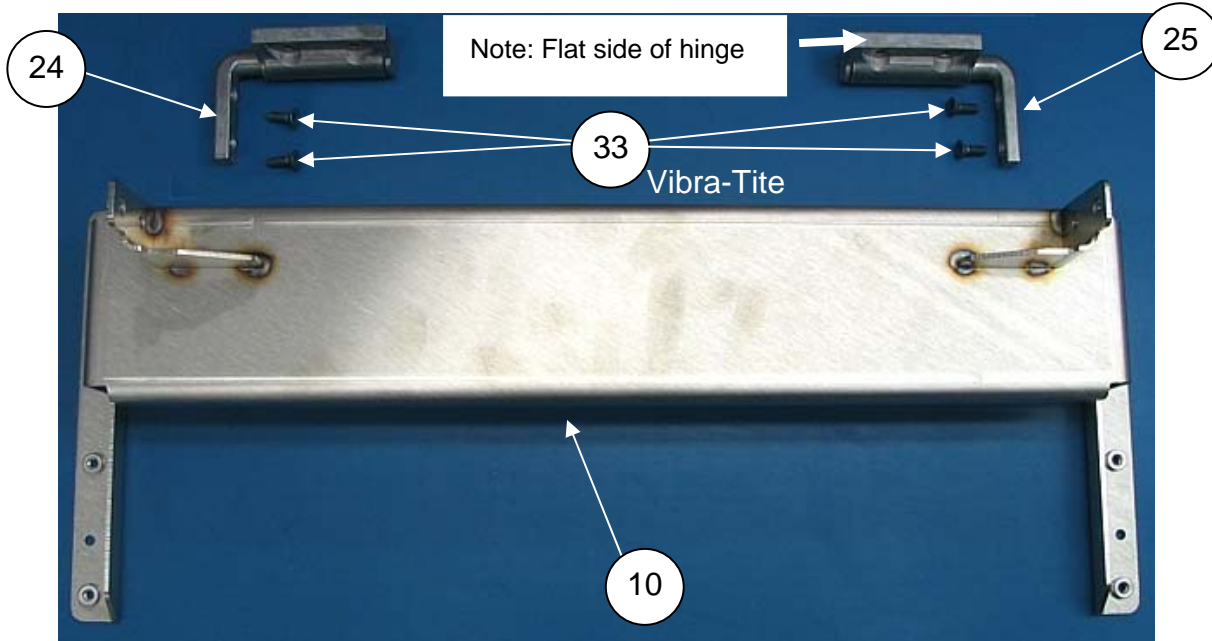

Use screws (Item 33, 4 Plcs), 2 per side to fasten the hinges to the inside of the bracket.

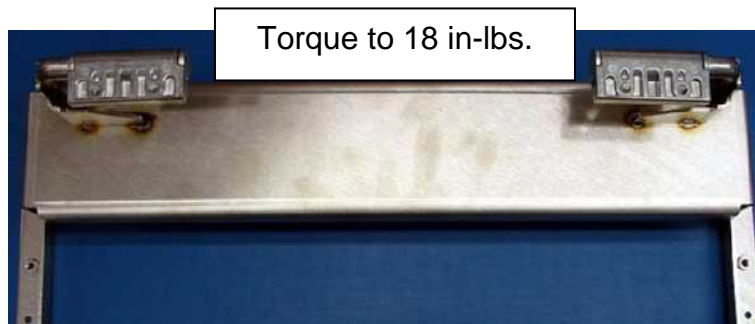

Using a small screw driver, adjust the each hinge so that it is perpendicular to the bracket as shown.

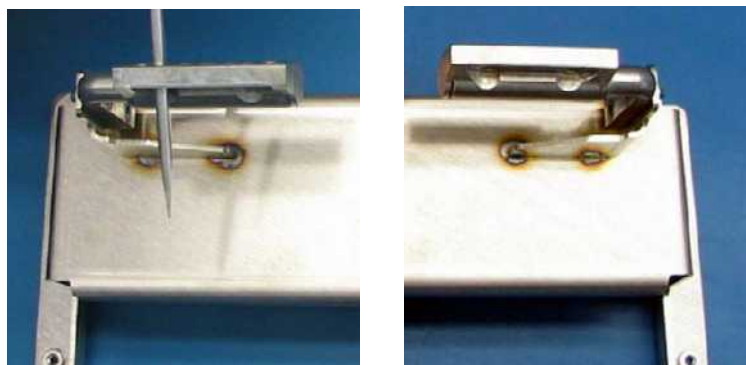

Apply Vibra-Tite (Item 30) to 4 Screws (Item 36). Mount hinge assembly to LCD Back Housing Assembly using Hinge Load Plate (Item 12, 2 Plcs) and Screws (Item 36, 4 Plcs). Torque 18 in-lbs.

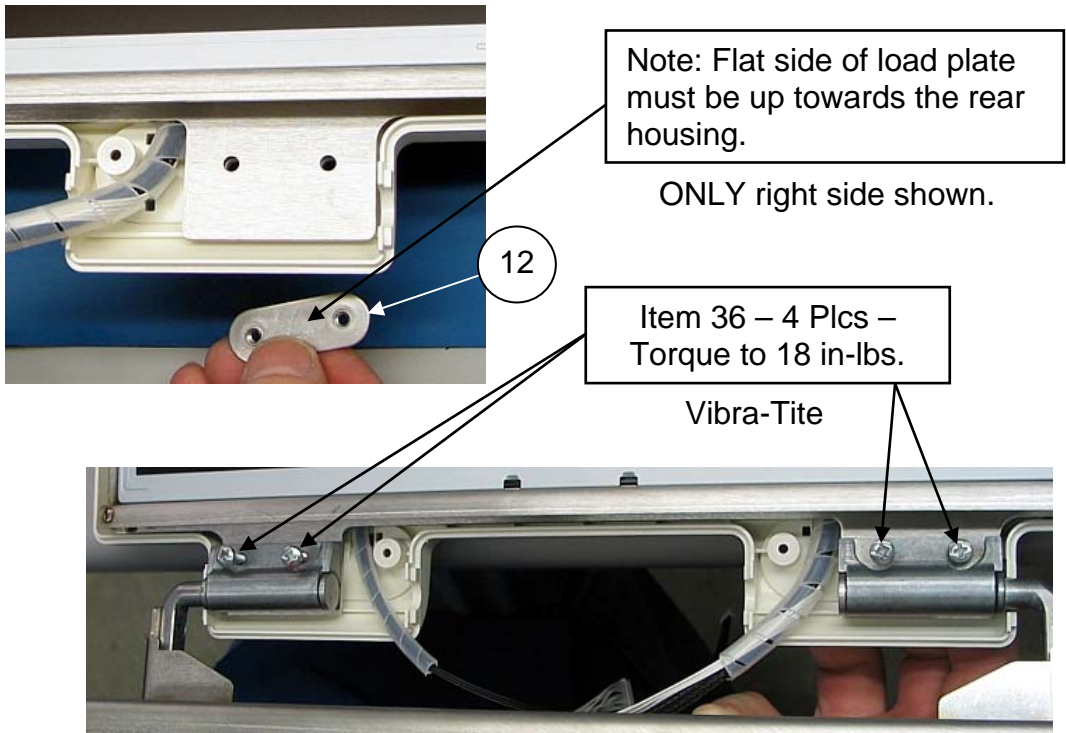

**Caution:** Route the cables to prevent any pinch points

Apply the card edge protector (Item 34) to right side only of the bracket on the edge shown.

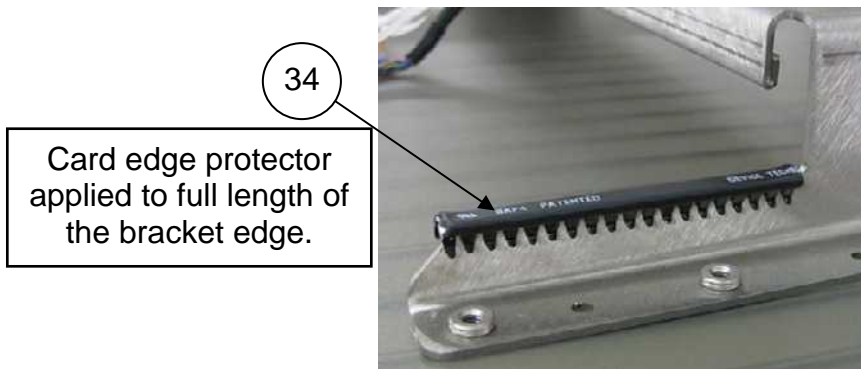

### **Final LCD Assembly**

Apply adhesive backed Lens Gasket (Item 16, Top & Bottom 2 Plcs), (Item 17, Sides 2 Plcs) to pebbled “dull” side of Protective Lens (Item 4).

**Caution:** Do not touch the lens surface with fingers as it may leave oils on the lens. Cotton gloves may be worn to reduce potential of touching the lens.

Ensure the foam tape is aligned with the edges of the lens.

At the corners, ensure the foam tape butts up to the adjacent piece of tape but does not overlap.

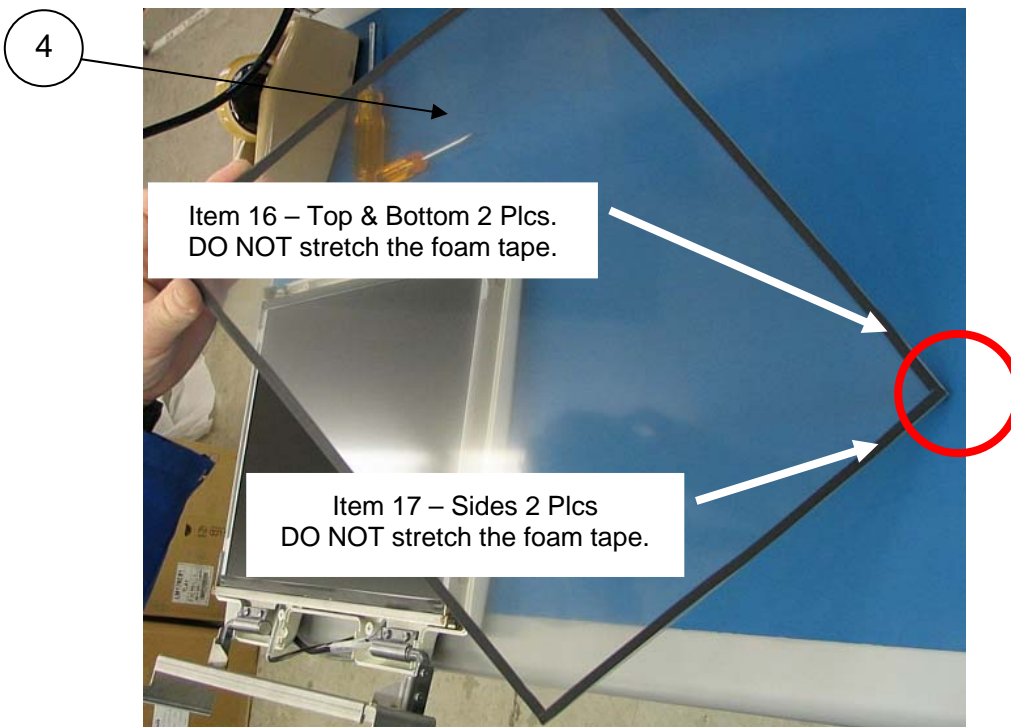

Clean LCD surface & lens with ionizing gun. Wipe clean with lens cleaner wipes if needed

Place protective lens on the LCD with the foam tape side up. Ensure the lens is seated properly allowing the LCD to float in the mounting bracket.



Assemble Front Bezel (Item 3) to the Rear Housing (REF: Item 1) using screws (Items 27, 4 Plcs).

Ensure cables are not pinched between the front and rear housings.

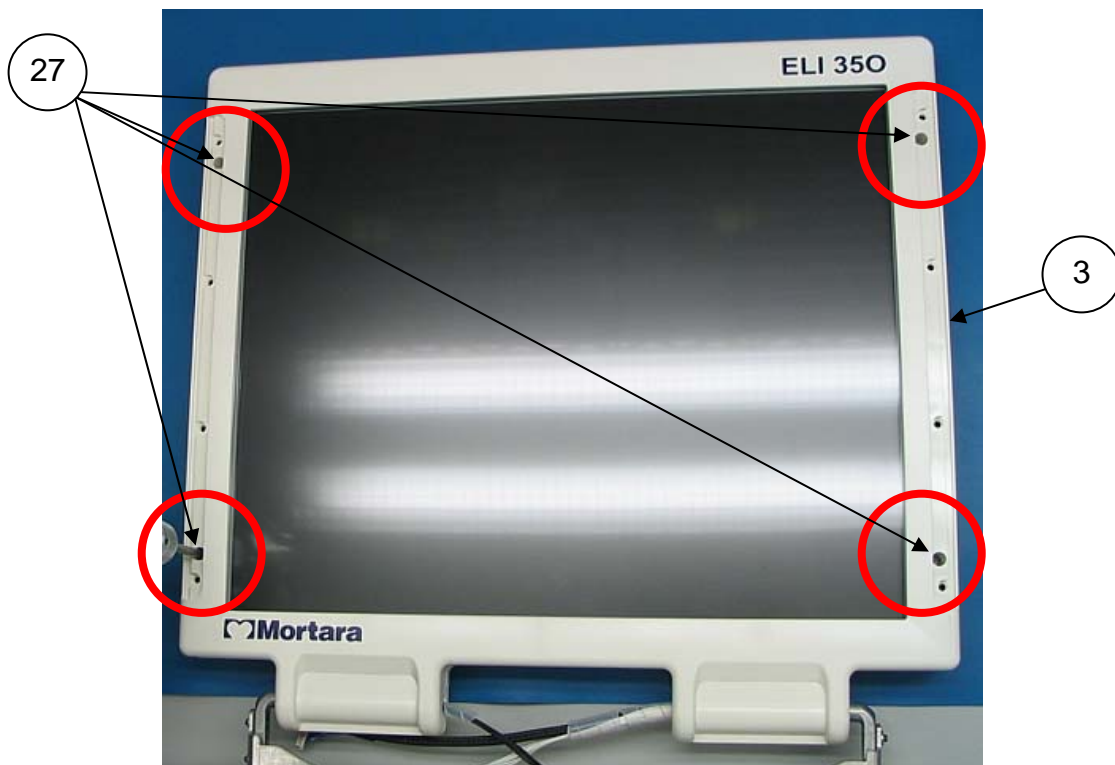

Flip the assembly over and fasten the Rear Housing to the Front Bezel using screws (Items 27, 4 Plcs).

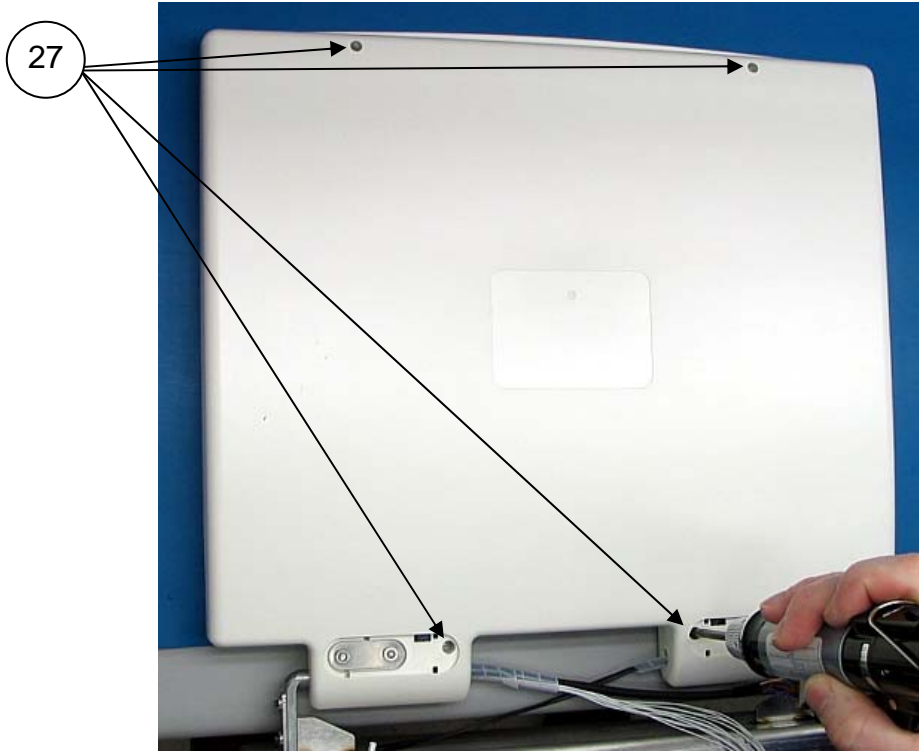

Snap the Cover Caps (Item 8 – Left & Item 7 – Right) in place. Ensure cap is fully seated. Note: Only left side is shown.

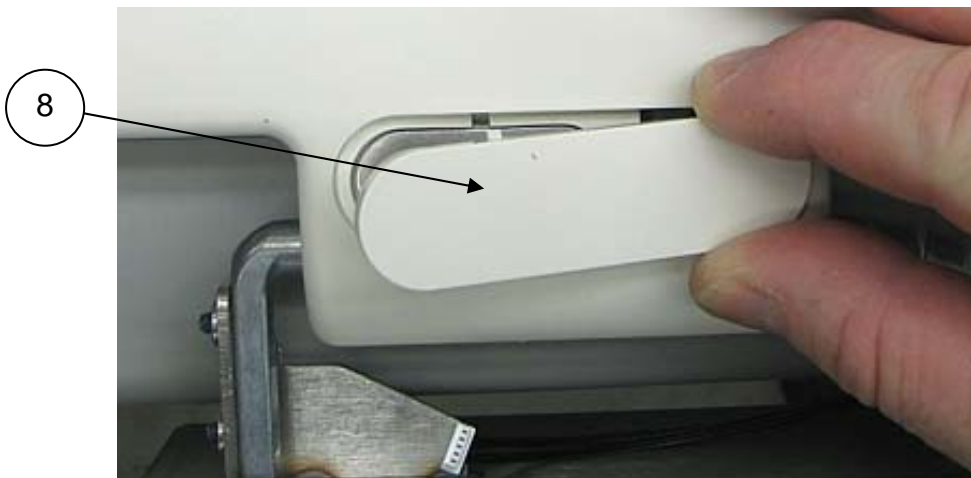

Cut two (2) Elastomeric Plugs (Item 13), to remove and discard the narrow half of the plug as shown.



Insert the Elastomeric Plugs in the top two (2) screw hole of the rear housing. Ensure the plugs are flush to the housing. Note: the beveled side of the plug must match the bevel of the rear housing.

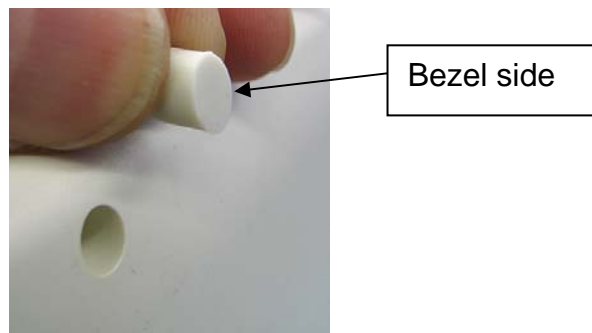

Apply Mortara label (Item 26) to Back housing in the recess provided.

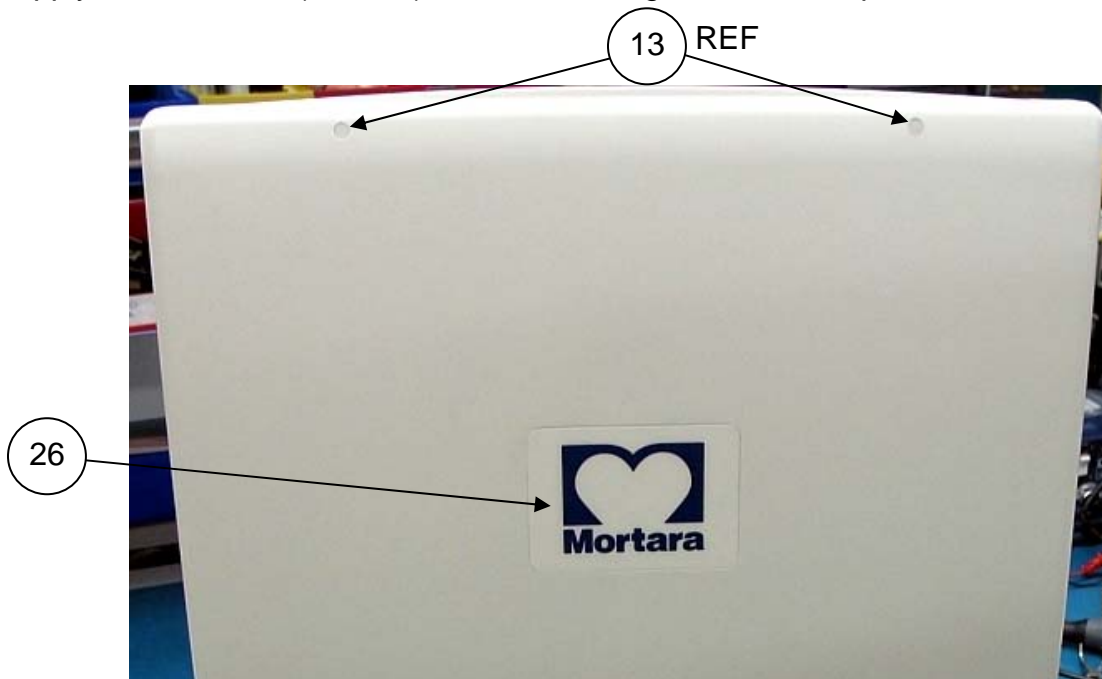

Snap the decorative LCD Bumper left (Item 6) and right (Item 5) to the Front Bezel.  
Clean the protective lens as required to remove all particles and finger prints.



Apply Tilt Switch Label (Item 15) to top of the finished display

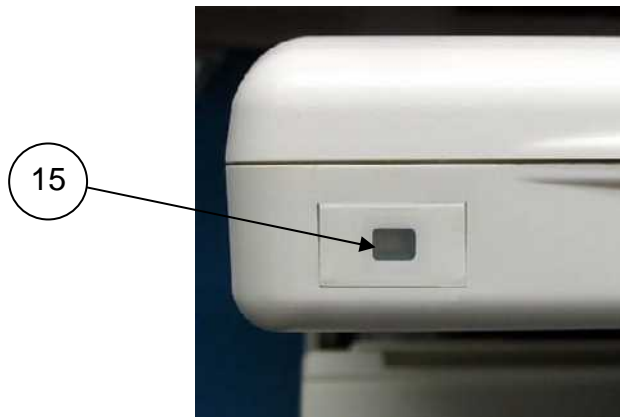



<b>ELI350 LCD Assembly</b>		
<b>Sequence #</b>	<b>Item Number</b>	<b>Item Description</b>
1	8351-010-50	HOUSING LCD PANEL REAR ELI 350
2	5400-016	LCD 17" COLOR ACTIVE MATRIX 1280 x 1024
3	8351-009-50	BEZEL LCD PANEL FRONT ELI 350
4	8351-018-50	LENS PROTECTIVE LCD ELI 350
5	8351-011-50	BUMPER LCD FRONT RIGHT ELI 350
6	8351-012-50	BUMPER LCD FRONT LEFT ELI 350
7	8351-013-50	COVER CAP LCD REAR RIGHT ELI 350
8	8351-014-50	COVER CAP LCD REAR LEFT ELI 350
9	9960-056	BACKLIGHT INVERTER MODULE CCFL QUAD 6W
10	8351-019-50	BRACKET ASSY MONITOR MOUNT ELI 350
11	8351-020-50	BRACKET ASSY LCD PANEL + HINGE ELI 350
12	8351-021-50	BRACKET LCD HINGE LOAD PLATE ELI 350
13	8351-022-50	PLUG ELASTOMERIC LCD HOUSING ELI 350
14	6001-006-01	SCREW SHOULDER HEX M3x0.5 STAINLESS 5mm
15	9042-058-01	LABEL TILT SW /LIGHT SENSE COVER ELI 350
16	8351-025-50	LCD LENS GASKET TOP / BOTTOM ELI 350
17	8351-026-50	LCD LENS GASKET SIDE ELI 350
18	8351-027-50	LCD LENS FOAM SUPPORT ELI 350
19	8351-028-50	LCD SUPPORT BLOCK ELI 350
20	25018-042-50	CABLE ASSY ELI 350 LCD TO MOTHERBOARD
21	25019-008-50	CABLE ASSY ELI 350 MTHRBD TO BKL T INVRTR
22	25019-009-51	CABLE ASSY ELI 350 TILT SWITCH TO MTHRBD
23	26025-082-50	ELI 350 TILT-SWITCH PCB ASSEMBLY
24	6422-005-01	HINGE POSITIONING CCW 4 Nm
25	6422-005-02	HINGE POSITIONING CW 4 Nm
26	9042-061-01	LABEL MORTARA LOGO 2.5 X 3.5
27	6020-831	SCREW PHILLIPS PANHD M3X8 ZINC PLTD
28	6024-001	SCREW M3 x 6 W/CAPTIVE LOCK WASHER
29	7400-019	TAPE POLYESTER FILM 1" X .05mm
30	7403-001	VIBRA-TITE 1oz
31	4175-021-01	TUBING SPIRAL WRAP FLEX 1/4" 94V-0 PE
32	4175-021-02	TUBING SPIRAL WRAP FLEX 3/8" 94V-0 PE
33	6030-008	SCREW CAP FLAT SOCKET HEAD M4X12mm STEEL
34	6300-011	GROMMET STRIP 0.069-0.090" / 1.7 - 2.3mm
35	7401-003	TAPE 2SIDED ADHESIVE 0.031 THK x.50 WIDE
36	6020-012	SCREW M4x0.7x16mm PHILLIPS PAN HEAD

### Writer Assembly

Note: Item numbers in this section refer to the parts on the writer BOM.

Slide Platen (Item 14) into Paper Cover (Item 16) as shown. The side with the longer shaft should go into the closed loop.



Slide the following items onto the longer side of the Platen in the order listed. The first Ball Bearing should slide into the closed loop on Paper Cover.

1. Ball Bearing (Item 12)
2. Small Spacer (Item 9)
3. Ball Bearing (Item 12)
4. Wave Washer (Item 7)
5. Large Spacer (Item 8)

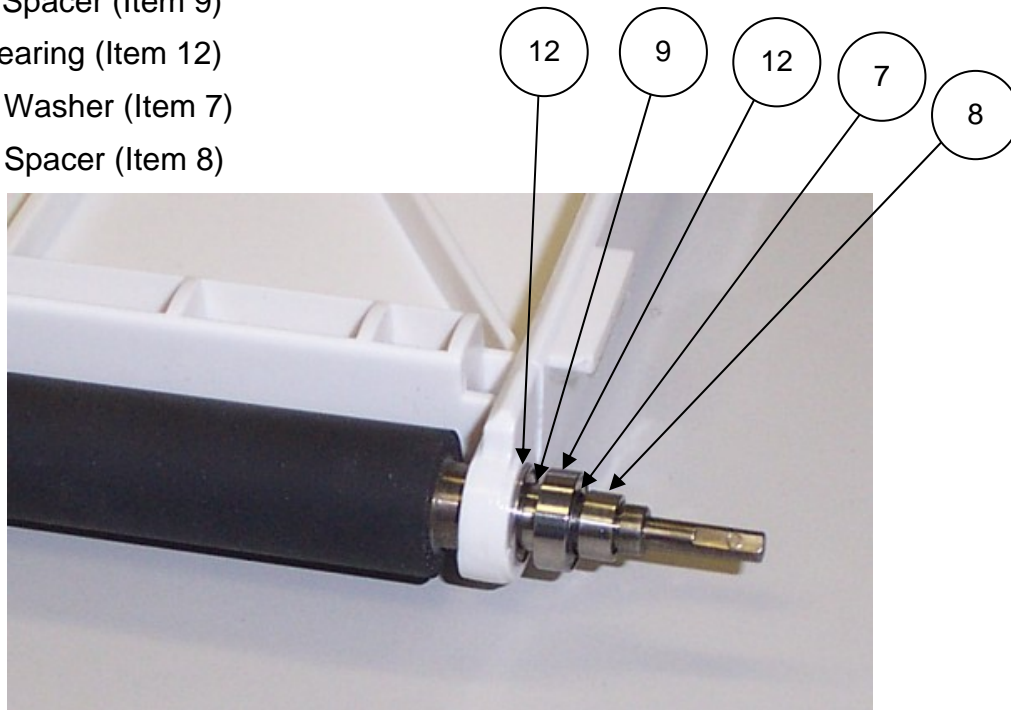

Lock the previous items in place with an E-Ring (Item 10) as shown. Make sure E-Ring snaps completely into the slot on the shaft.

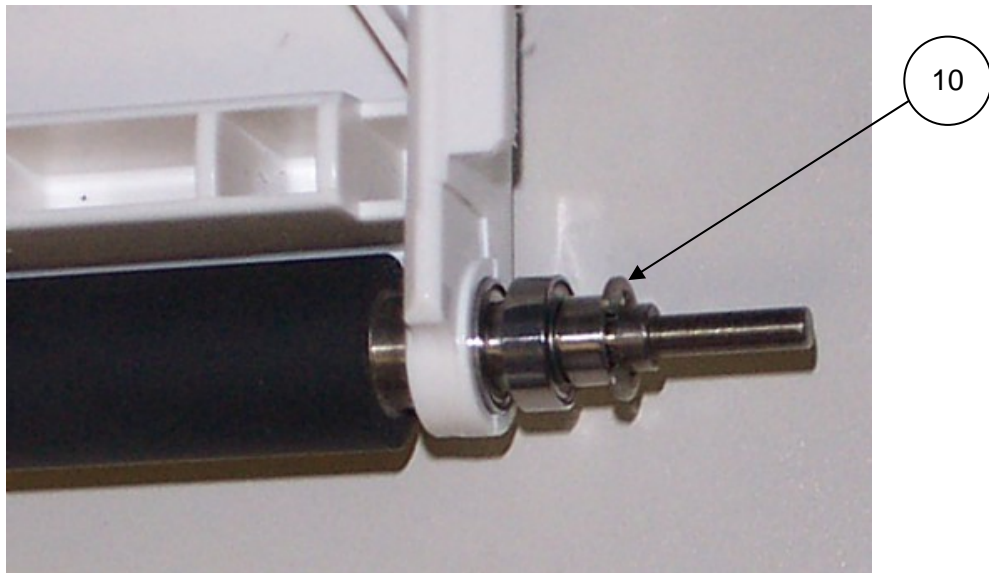

Slide the following items onto the shorter side of the Platen in the order listed. The first Ball Bearing should slide into the open loop on Paper Cover.

1. Ball Bearing (Item 12)
2. Small Spacer (Item 9)
3. Ball Bearing (Item 12)
4. Small Spacer (Item 9)

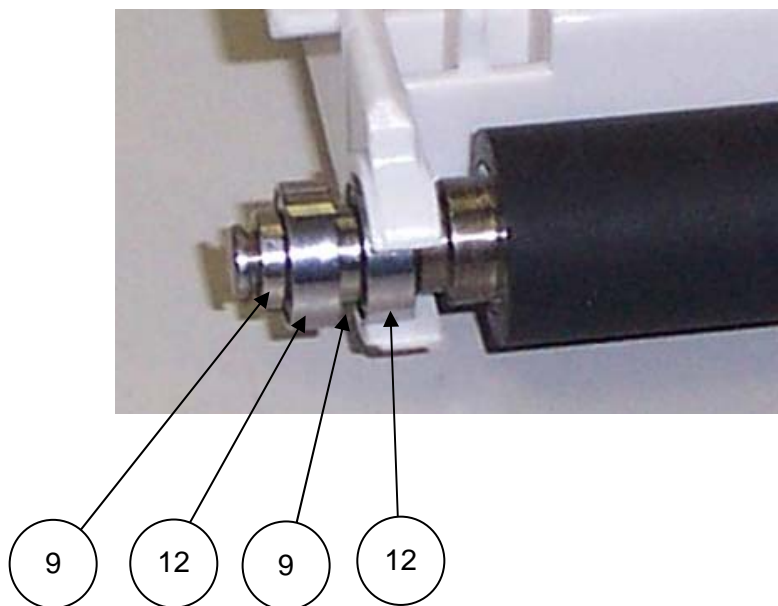

Lock the previous items in place with an E-Ring (Item 10) as shown. Make sure E-Ring snaps completely into the slot on the shaft.

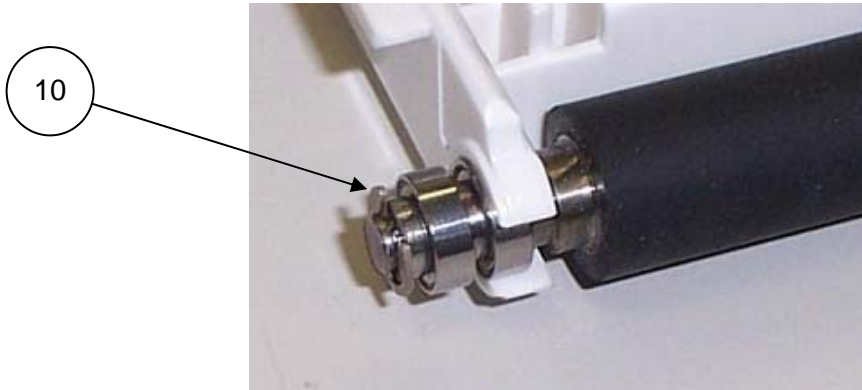

Prepare two Set Screws (Item 6) by brushing Vibra-Tite (Item 31) onto the threads. Allow to dry for a minimum of 10 minutes. Note: This step may be done prior to assembling the unit so the Vibra-Tite has time to dry and the screws are ready to install. If the parts already have Vibra-Tite on the threads this step can be skipped.

Install Vibra-Tite (Item 31) prepared Set Screw (Item 6) partially into Single Gear (Item 22). Slide Single Gear completely onto longer shaft on Platen. Align Set Screw with flat part on Platen shaft. Tighten Set Screw to secure Single Gear to Platen shaft as shown. Spin Platen Shaft and verify it spins freely.

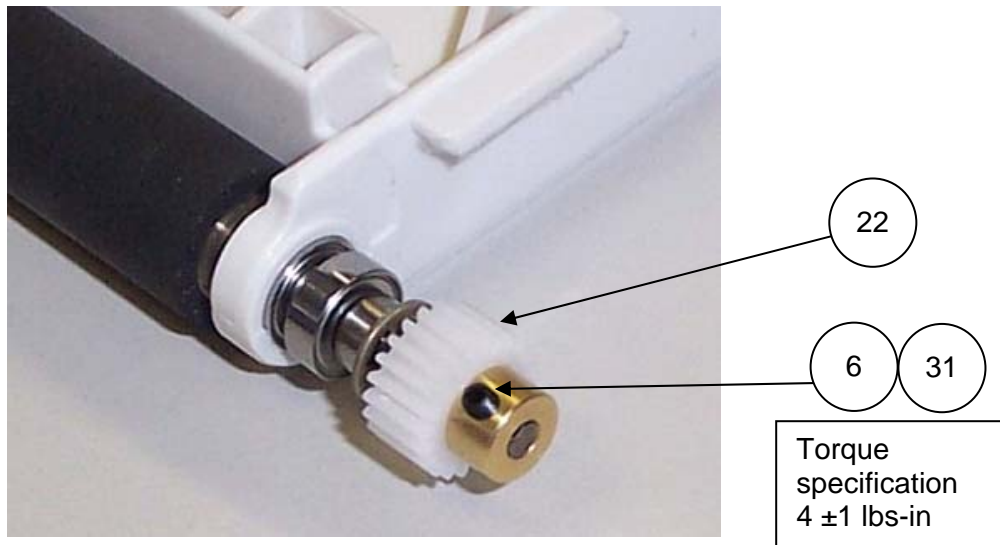

Visually inspect the Cue Sensor PCB (Item 30) before installing it in the Paper Tray (Item 18). Place Cue Sensor PCB onto Paper Tray as shown. **Make sure Cue Sensor PCB is flush against Paper Tray.** Place a drop of Adhesive (Item 32) on two posts to secure Cue Sensor as shown.

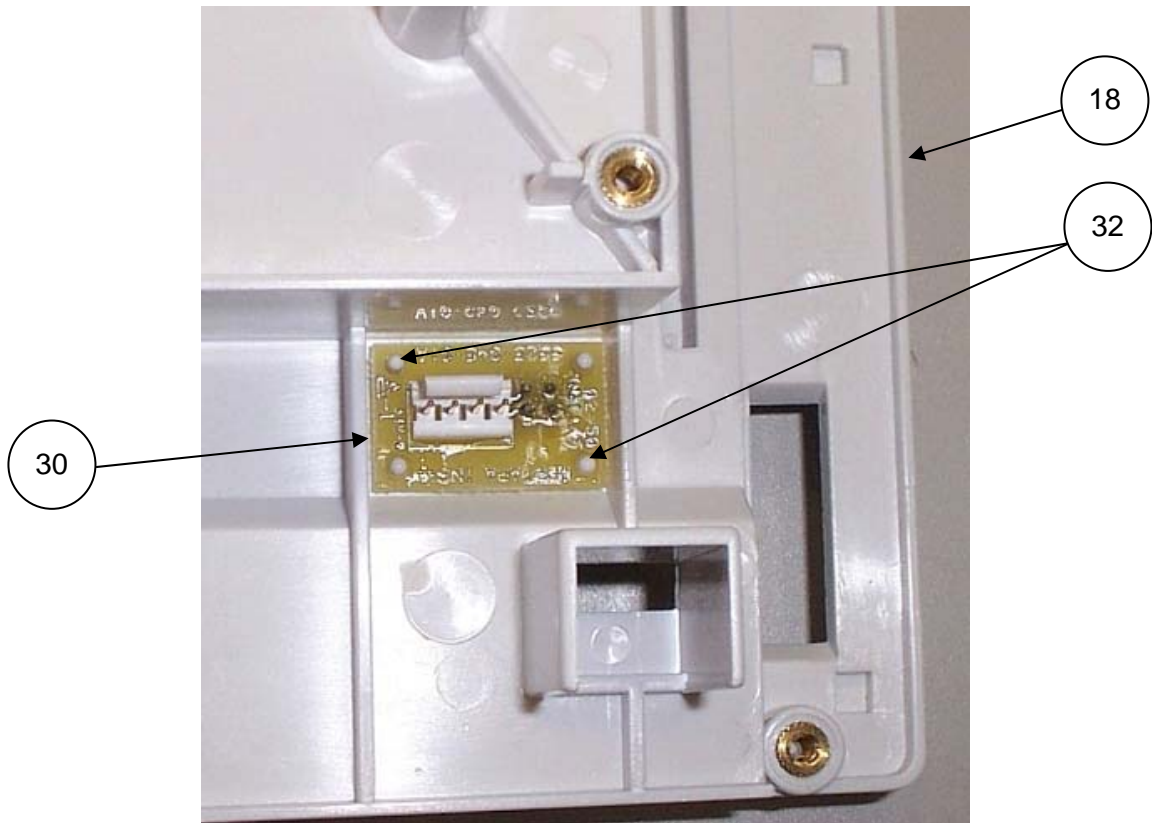

Connect Cue Sensor Cable (Item 29) to Cue Sensor PCB as shown.

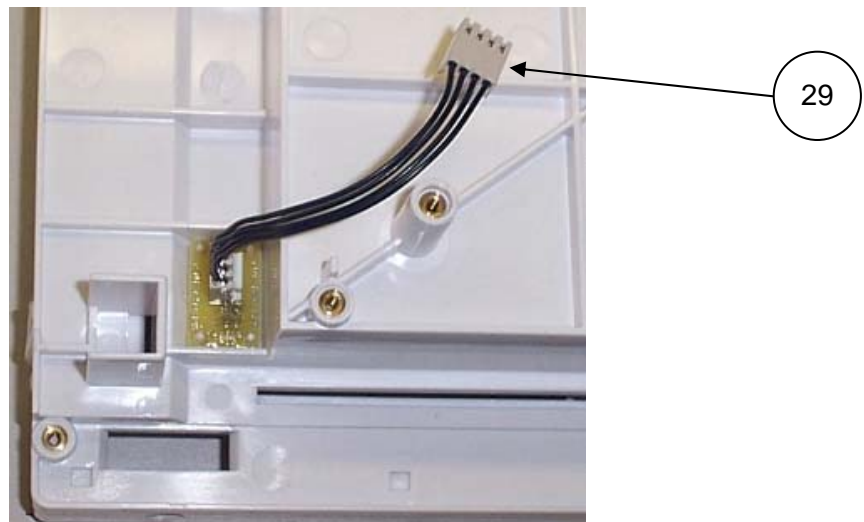

Prepare two Screws (Item 4) by brushing Vibra-Tite (Item 31) onto the threads to mount the stepper motor to the gear box. Allow to dry for a minimum of 10 minutes. Note: This step may be done prior to assembling the unit so the Vibra-Tite has time to dry and the screws are ready to install. If the parts already have Vibra-Tite on the threads this step can be skipped.

Orient and attach Stepper Motor to Gear Box (Item 17) with the two Screws (Item 4) as shown. Grip the gear box as shown in the second photo. Press the stepper motor in the direction of applied force as indicated in the second photo. Secure the stepper motor to the gear box.

Orient Stepper Motor with wire connection in this location.

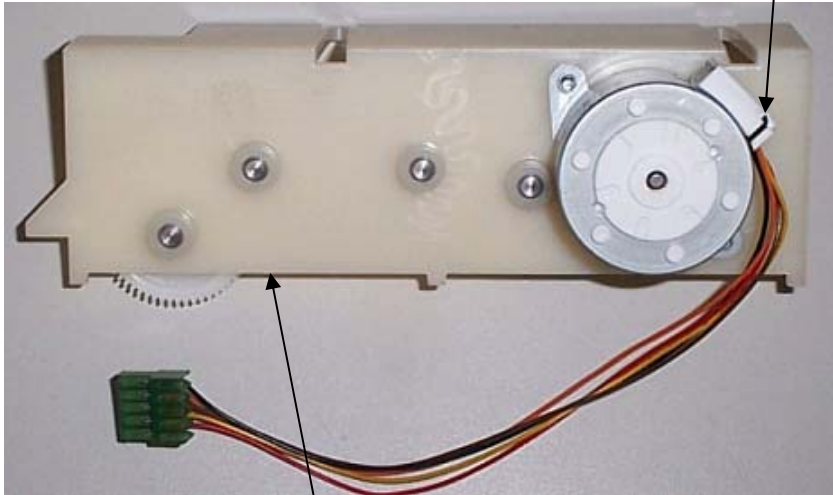

17

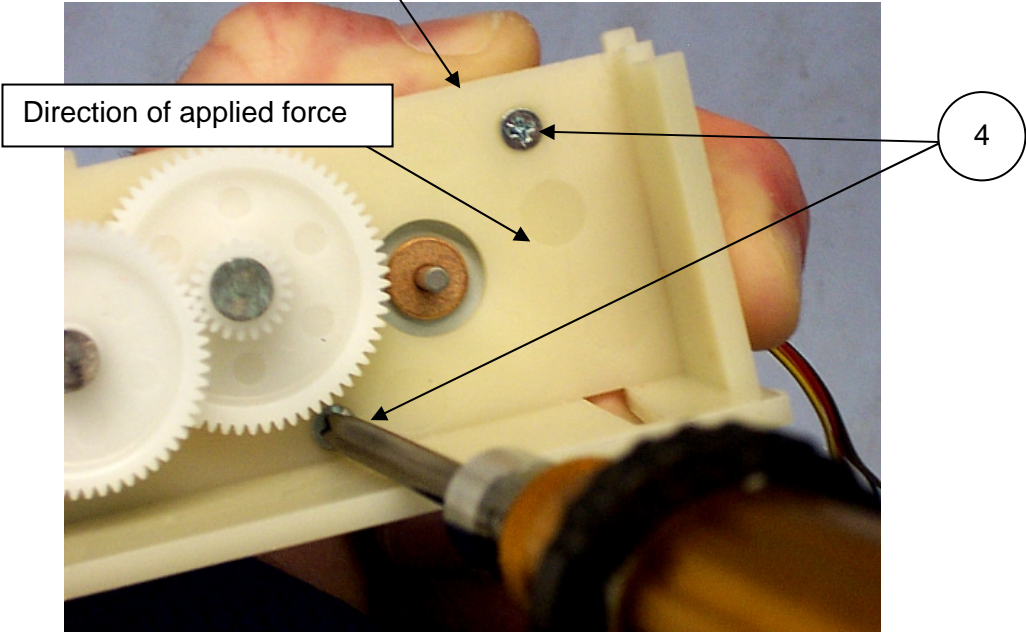

Direction of applied force

4

17

Install Vibra-Tite (Item 31) prepared Set Screw (Item 6) partially into Single Gear (Item 22). Slide Single Gear onto the shaft of the Stepper Motor (Item 13). Align the stepper motor gear flush with the edge of the large gear with which it meshes. Tighten Set Screw to secure Single Gear to Stepper Motor. Using your thumb, rotate the large gear to ensure smooth operation of the gear train.

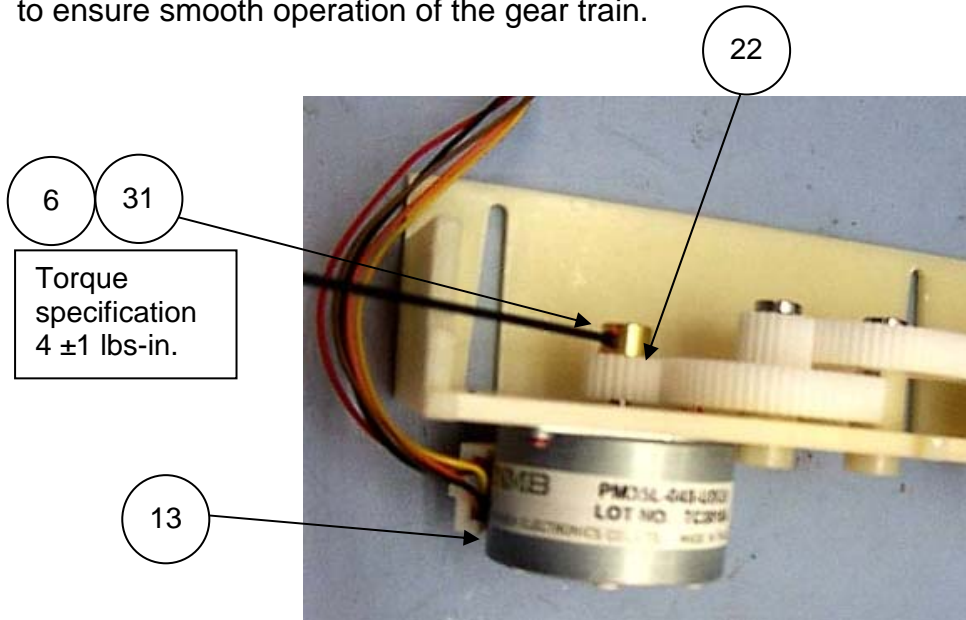

Prepare three Screws (Item 5) by brushing Vibra-Tite (Item 31) onto the threads as shown. Allow to dry for a minimum of 10 minutes. Note: This step may be done prior to assembling the unit so the Vibra-Tite has time to dry and the screws are ready to install. If the parts already have Vibra-Tite on the threads this step can be skipped.

Place Gear Box assembly onto Paper Tray and secure with three screws (Item 5) as shown. Make sure the three alignment posts on the Gear Box mate with the three alignment holes on the Paper Tray.

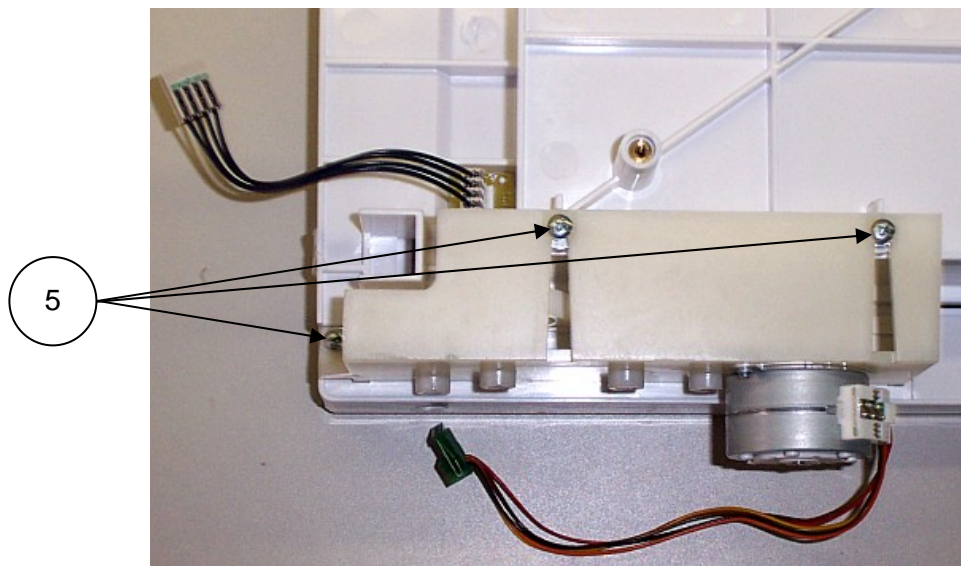

Place Paper Cover into Paper Tray as shown. Mate parts by aligning tabs on Paper Cover with slots on Paper Tray.

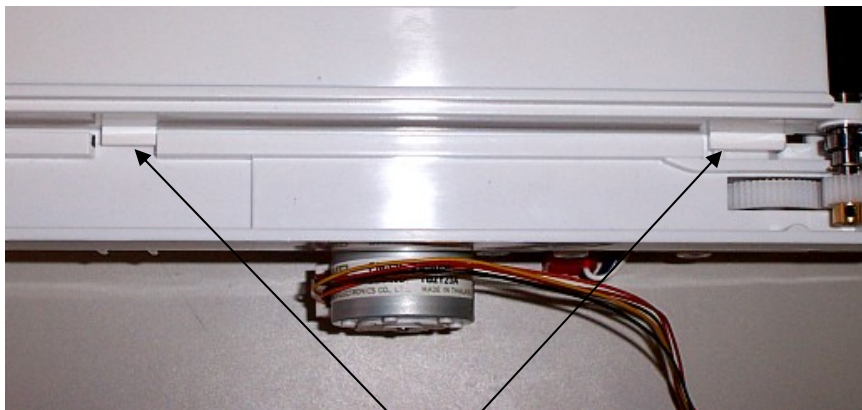
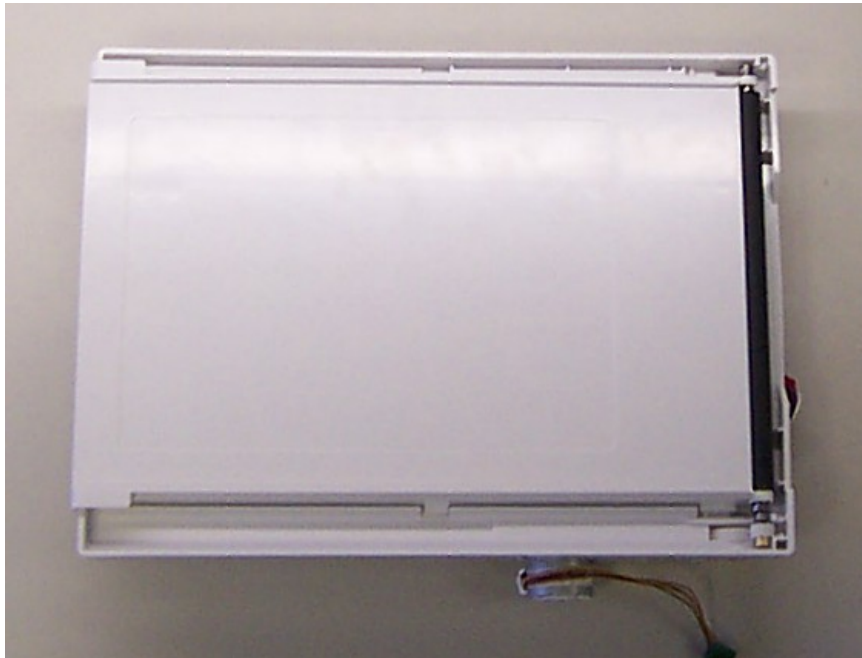

Align Tabs to slots  
when mating



Slide Pivot Bar (Item 24) into Latch Release (Item 21) as shown.

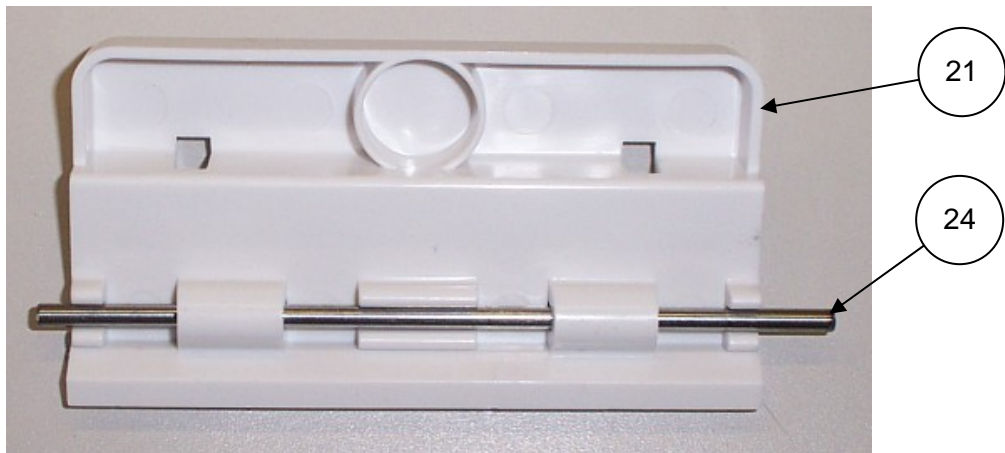

Slide Paper Cover half way open and turn upside down. Place Compression Spring (Item 25) onto Paper Cover as shown.

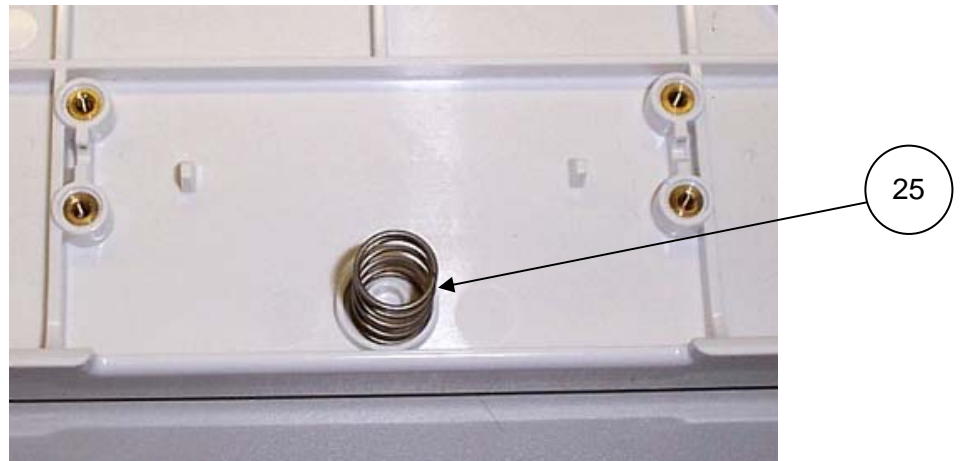

Place Latch Release with Pivot Bar installed onto Compression Spring as shown. Make sure Compression Spring sets in the spring capture area provided on Latch Release.



Place a Pivot Bar Restraining Plate (Item 26) over each end on the Pivot Bar and secure with four Screws (Item 4) as shown. Make sure Latch Release moves freely. Close and open the Paper Cover and verify it latches and releases properly. Leave Paper Cover open.

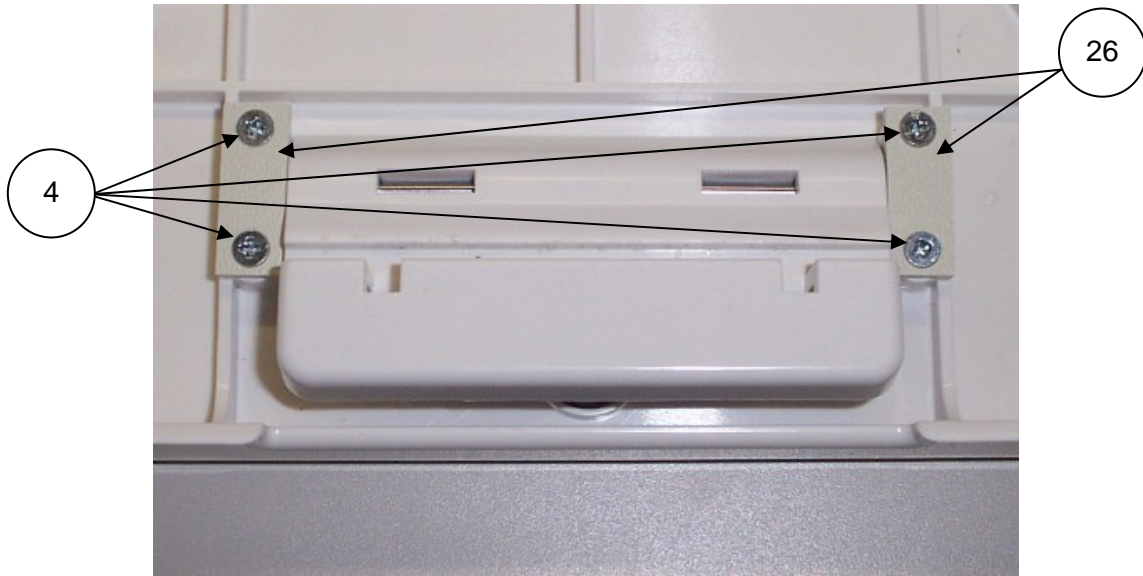

Mark the center (approximately 4.55 inches from one side) of the Print Head (Item 1). Remove protective backing from the Anti-Static Brushes (Item 15) and adhere to the Print Head as shown. Align edge of both pieces with brushes extending past Print Head. Center Anti-Static Brushes approximately 0.1 inches from the center mark. This will leave approximately 0.2 inches between the Anti-Static Brushes.

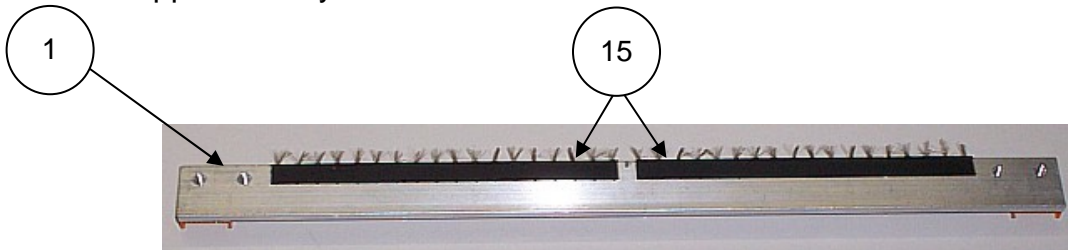

Connect Print Head Cables (Item 27) and (Item 37) to Print Head as shown.



Place Print Head into Print Head Mount (Item 19) and secure with two shoulder screws (Item 34) and screw (Item 5). Attach ground wire (Item 28) with screw (Item 35) as shown.

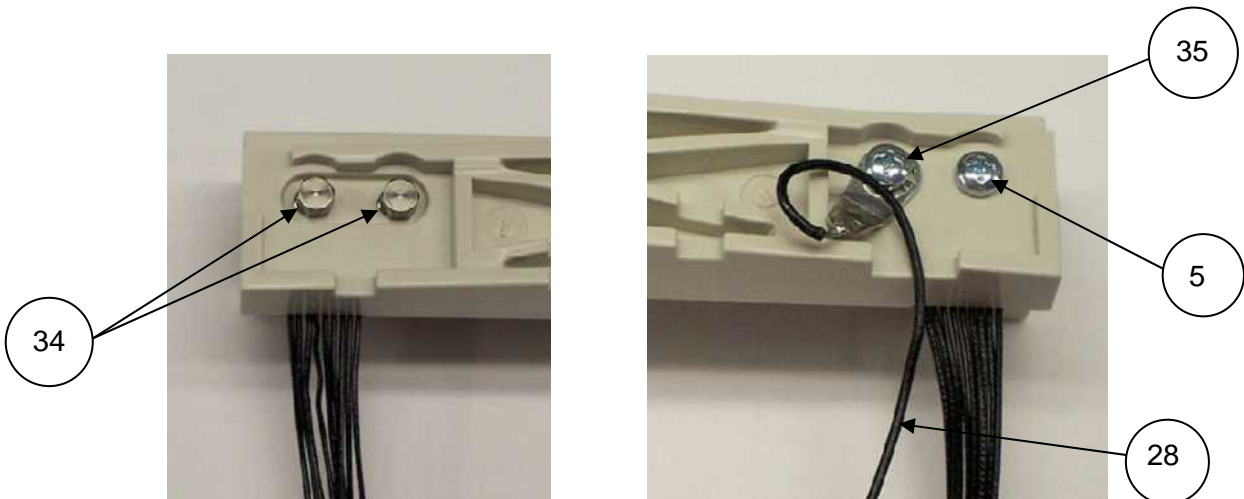
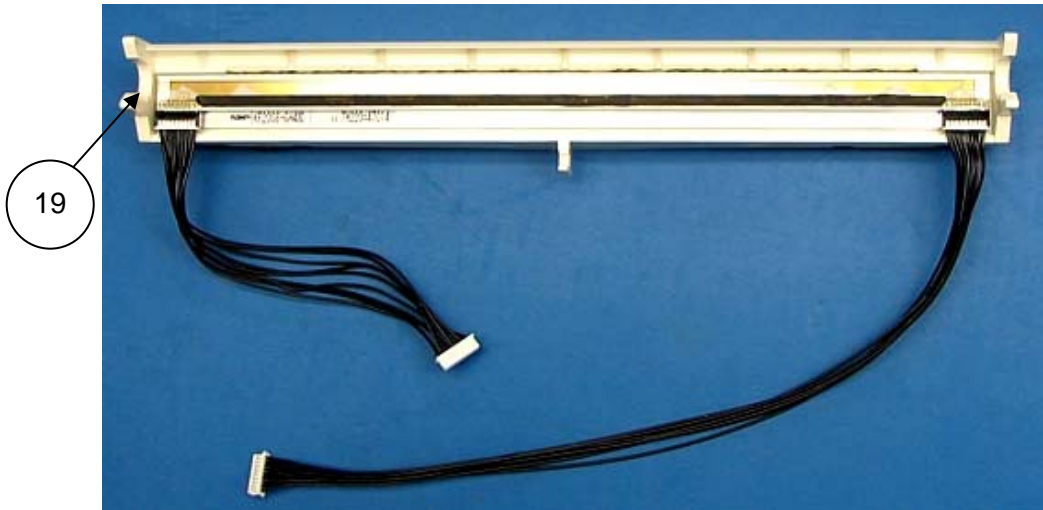

Route Print Head Connectors down through Paper Tray as shown.

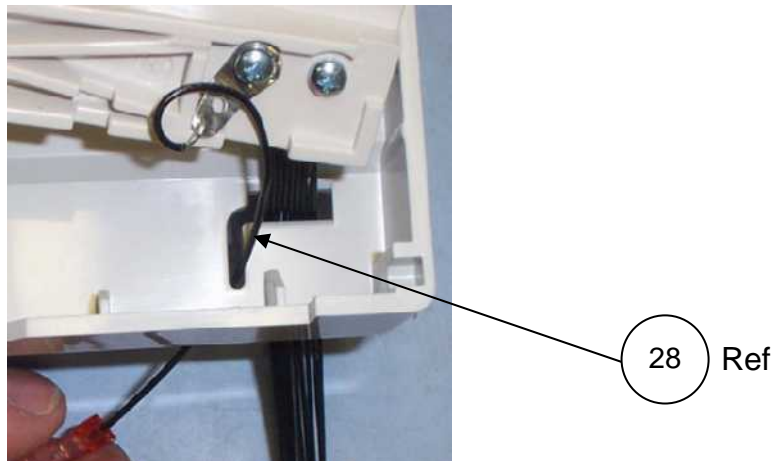

Place Print Head Mount into Paper Tray and secure with O-Ring (Item 11) as shown.

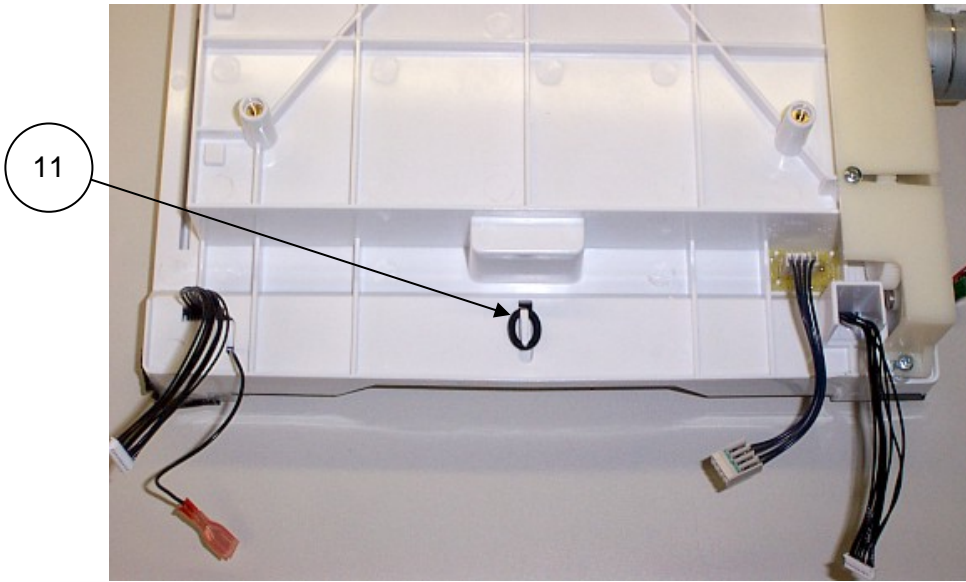

Slide the 2 spring bar retention clips (Item 36) over the spring bar (Item 23) as shown.

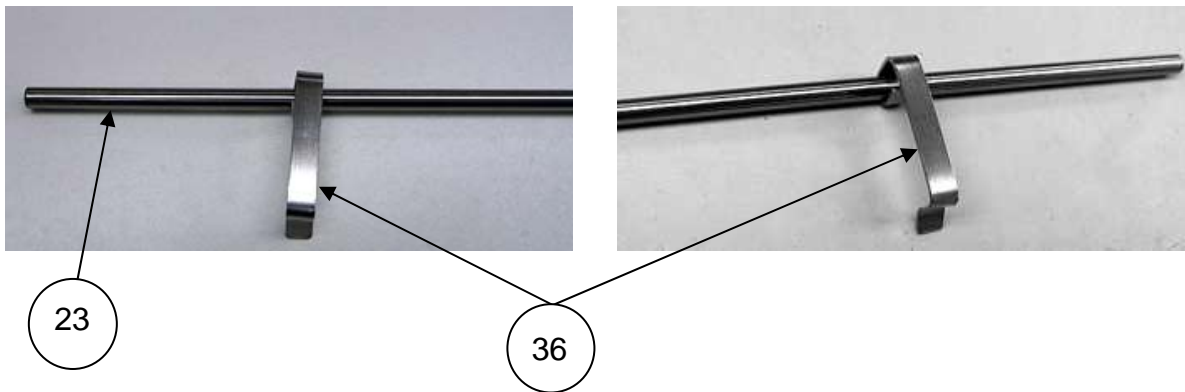

Place Spring Bar (Item 23, ref) in place as shown.



Snap the Retention Clips to the writer tray as shown. Open and close the writer cover drawer to verify proper operation ensuring there is no interference with the retention clips.

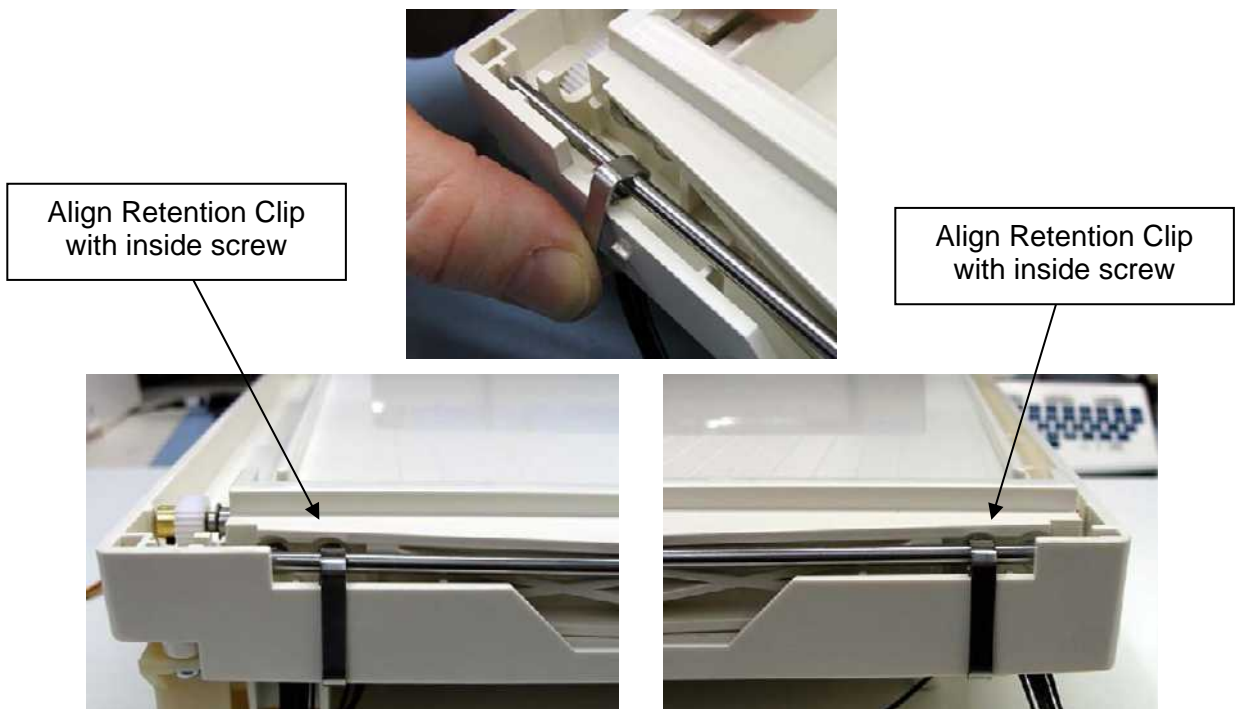

<b>ELI350 Writer Assembly</b>		
<b>Sequence #</b>	<b>Item Number</b>	<b>Item Description</b>
1	5450-004	PRINTHEAD THERMAL 216mm 8.50"
4	6020-730-02	SCREW PHILLIPS FLAT M3 x 6 ZP COATED
5	6020-831-02	SCREW PHILLIPS PANHD M3X8 ZP COATED
6	6030-025	SET SCREW SOCKET M2.5 x 4
7	6100-004	WASHER, WAVE, .006/.030 x .18 x .25
8	6125-004	SPACER .19 x .25 x .125
9	6125-017	SPACER .19 X .25 X .063
10	6140-003	E-RING, .187 SHAFT, SS
11	6141-003	O-RING BUNA-N 1/2 OD X 5/16 ID
12	6520-003	BEARING BALL .1875ID SS
13	6545-006-02	MOTOR STEPPER PM 35mm 1-2PH 48 ST/REV XL
14	6570-842-02	PLATEN / SHAFT 8.421 X .551
15	7480-090	BRUSH ANTI-STATIC 90mm FLEXIBLE
16	8342-003-50	PAPER TRAY COVER ELI 200+
17	8342-004-50	GEAR BOX ASSEMBLY ELI 200+
18	8342-005-50	PAPER TRAY ELI 200+
19	8342-006-02	PRINTHEAD MOUNT ELI 200+
21	8342-008-01	LATCH RELEASE ELI 200+
22	8342-009-01	GEAR SPUR 22 TEETH WITH STAINLESS HUB
23	8342-017-01	SPRING BAR 10.125 X .156 DIA.
24	8342-018-01	BAR RELEASE PIVOT 3.950 X .118 DIA.
25	8342-019-01	SPRING COMPRESSION .5 OD X .85 L
26	8342-020-01	PIVOT BAR RESTRAINING PLATE
27	25018-034-50	CABLE ASSEMBLY ELI 200+ PRINTHEAD TO PCB
28	25020-058-50	GROUND WIRE FOR ELI 200+ PRINTHEAD
29	25020-066-50	CABLE ASSY ELI 350 CUE SENSOR TO MTHRBD
30	26025-045-51	ELI 200+ CUE SENSOR PCB ASSEMBLY
31	7403-001	VIBRA-TITE 1oz
32	9326-002	ADHESIVE CYANOACRYLATE ESTER
34	6001-002-01	SCREW, SHOULDER HEX M3 x 0.5 STAINLESS
35	6020-831	SCREW PHILLIPS PANHD M3X8 ZINC PLTD
36	8342-025-50	RETAINER CLIP ELI 2XX WRITER SPRING BAR
37	25018-041-50	CABLE ASSEMBLY ELI 350 PRINTHEAD TO PCB

## **4 Troubleshooting and Testing**

### ***Introduction***

Since repair of the ELI 350 is limited to replacement of subassemblies the troubleshooting guide does not extend to the component level

**NOTE: Remove the battery fuse and AC power during any disassembly necessary for servicing.**

### ***Troubleshooting***

#### **AC power connected to unit, back-light is on, nothing on display.**

- 1) Check AC fuses.
- 2) Does unit power up on battery?
  - A) If yes, there is an AC power supply problem. Replace the motherboard.
  - B) If no, power supply or battery problem. Replace motherboard and check battery for possible replacement.
- 3) Check Keyboard/LCD cable going to the keyboard and the motherboard. If disconnected reconnect and test again.
- 4) Replace the Keyboard/LCD cable.

#### **With AC power on nothing displayed on LCD**

- 1.) Press any key on the keyboard. If speaker tone is heard there is a possible LCD problem. Replace LCD.

#### **Unit works on AC power but not on battery**

- 1) Check battery fuse.
- 2) Open unit and check battery connections.
- 3) Replace battery.

#### **Unit does not dim display in a darkened room**

- 1) Go to the settings screen and verify the Brightness AC and Brightness Battery settings are set to Auto.
- 2) If not set them to Auto.
- 3) Save the settings.
- 4) Back at the main screen, cover the light sensor on the top left corner of the screen housing, and the screen should begin to dim in 1 second intervals.
- 5) Uncover the sensor, and the screen should brighten again.

**Unit turns on, no waveform is displayed on the LCD.**

Press any key on the keyboard, if no response there is a possible communications problem between front end board and motherboard.

- 1) Replace cable between front end and motherboard.
- 2) Replace front end board
- 3) Replace motherboard

**No keyboard functions and LCD is frozen**

- 1) Remove AC power.
- 2) Remove battery fuse from unit and leave out for 10 seconds.
- 3) Install battery fuse.

**RS-232 Transmit/Receive Problems**

Make sure that the baud rate set in the configuration matches that of the system that is being transmitted to or received from. If the baud rate is set correct there is a problem with either the transmission cable or the RS232 portion of the motherboard and the motherboard should be replaced.

**Optional Modem Transmit/Receive Problems**

If the unit does not transmit via the modem the first item to check is the configuration. Make sure that a telephone number is entered and that the number is correct. The next item to check is the modem initialization string (please see the configuration section of this manual or the operator manual).

**Unit does not go into standby mode**

If the unit does not go into "Stand-by" mode when the LCD is lowered, check the cable connections from the Tilt-switch assembly to the motherboard. If this connection is OK, inspect the cable for damage or loose connections.

**Unit appears to be "Locked-up"**

The ELI-350 unit is equipped with a software reset function that can be used to remove the unit from an unresponsive state. This can be done by holding the ON/OFF button down for 8 seconds, and then releasing the button.



## **Testing**

### **Power Supply Test**

- 1.) Remove battery fuse and AC power from the unit.
- 2.) Open unit to access the connections to the battery.
- 3.) Remove one of the battery cables from its terminals.
- 4.) Connect DMM set to a current setting to measure the current that the unit is using.
- 5.) Install the battery fuse.
- 6.) Set the DMM to the 10A range.
- 7.) Turn the unit on and measure the current draw from the battery. This should read less than 2.7 Amps.
- 8.) Verify that the AC LED on the keyboard is not on.
- 9.) Apply AC power to the unit and verify that the current reading on the battery does the following
  - A.) Reverses polarity
  - B.) That the value starts decreasing as time increases.This indicated that the battery is charging.
- 10.) Remove AC power and the battery fuse.
- 11.) Remove the DMM and reconnect the battery cable to the battery.
- 12.) Close the unit.

### **Keyboard Test**

- 1.) Turn Unit on.
- 2.) Use the click knob to select the ID field.
- 3.) Start pressing the alpha keys on the keyboard and verify that they are displayed on the screen. When the characters reach the end of the line, press the enter key and continue entering characters in the First Name field.
- 4.) If all characters are present the test has passed. If any of the characters are not displayed there is a possible keyboard problem.

### **LCD Test**

- 1.) Turn the unit on.
- 2.) Apply an input signal from a simulator.
- 3.) Verify that there are no gaps, missing segments or large black areas on the screen.
- 4.) Enter the configuration of the unit.
- 5.) Locate the Contrast setting for the display.
- 6.) Change the contrast setting to full and then decrease the setting. Verify that the screen goes fully dark and then blank.
- 7.) Reset the contrast to an acceptable level.

### **Speaker Test**

- 1.) Turn the unit on.
- 2.) Turn the click knob or press keys on the keyboard.

### **Date / Time Test**

- 1.) Turn the unit on.
- 2.) Go to the settings menu and change the date and time.

**Writer Tests**

- 1.) Turn the unit on.
- 2.) Take an ECG using the method described in the operator manual.

**Note: This test should be performed with the AC power connected to the unit.**

*Description of printout*

The ECG that is printed should be clean, without missing segments. When printing an ECG at different paper speeds the calibration pulse printed at the beginning of each trace can be used to check the paper speed. Check the calibration pulse by measuring the width and amplitude of the pulse at the beginning of each line of ECG tracing. Use the following table for the correct measurements.

**Note: The measurements should be made using a ruler and not the grid on the paper.**

<b>Paper Speed</b>	<b>Cal Pulse Width</b>
5mm/sec	1mm
10mm/sec	2mm
25mm/sec	5mm
50mm/sec	10mm
<b>Gain Setting</b>	<b>Cal Pulse Amplitude</b>
5mm/mV	5mm
10mm/mV	10mm
20mm/mV	20mm

**Adjusting the Writer Cue Sensor**

**Note: This test should be performed with the AC power turned on.**

- 1) Install paper into the unit with the cue mark approx. 1 – 2 inches away from the tear bar. Make sure that the cue sensor is seeing white and not any markings on the paper.
- 2) Use a DMM to measure the DC voltage at test point P15 on the motherboard with respect to ground (GND5). Adjust R271 on the motherboard to between 1.95 V-DC and 2.05 V-DC at test point P15. Set this as close to 2.0 V-DC as possible.
- 3) Perform either the Writer test or print a test ECG. The paper should cue to the next sheet of paper, print and then advance to the beginning of the next sheet of paper.
- 4) If the Writer test is performed the results should be compared with the test printout in this manual.

**ECG Test**

- 1.) Connect a simulator to the patient cable and connect the patient cable to the unit.
- 2.) Turn the unit on.
- 3.) Enter the ID screen and enter a test patient name.
- 4.) Press the Auto key. The unit will acquire the ECG and depending on the units' configuration, will print the ECG.
- 5.) Verify that the printed ECG is correct for the simulated input to the unit.

## Noise Test

Perform the noise test using a shorting plug of the following design.

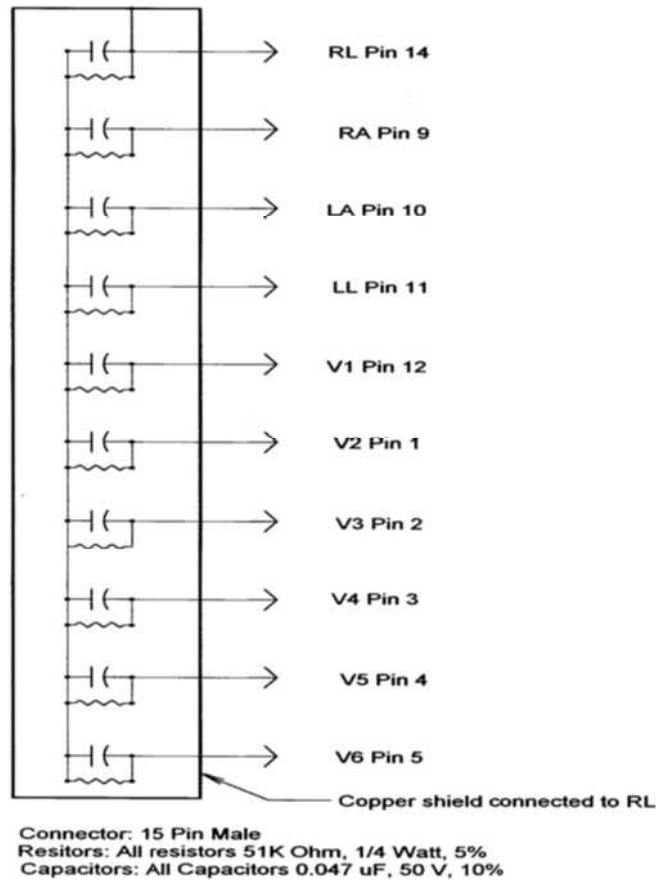

**Please note that Mortara Instrument does not supply this shorting plug**

- 1.) Turn the unit on with the shorting plug connected to the input connector of the unit.
- 2.) Increase the gain of the unit to 20mm/mV.
- 3.) Select the **RHY** button to print a rhythm strip.
- 4.) After 200 mm of paper have printed, press the **Stop** button to stop the printout.
- 5.) Visually inspect the baseline of the rhythm strip for any peaks greater than 0.5 mm. If there are no peaks greater than 0.5mm the test is successful.

**Lead Fail Test**

Perform the lead fail test as follows:

Connect the patient cable to a simulator or a shorting bar. Disconnect one lead at a time from the simulator or shorting bar and verify that the correct lead fail message appears on the upper right corner of the LCD. Only the message for the disconnected lead should appear as shown below.

<b>Lead</b>	<b>Message</b>
Right Arm	LEAD RA OFF
Left Arm	LEAD LA OFF
Left Leg	LEAD LL OFF
V1	LEAD V1 OFF
V2	LEAD V2 OFF
V3	LEAD V3 OFF
V4	LEAD V4OFF
V5	LEAD V5 OFF
V6	LEAD V6 OFF
All Leads off	LEADS OFF

**Transmitting Records**

You may transmit ECGs from the ELI 350 to another Mortara Instrument electrocardiograph or to an E-Scribe Data Management System using a direct connection or an optional factory installed internal modem.

Before transmitting ECGs to E-Scribe, the site number must be defined as well as the telephone number in the configuration.

***NOTE: Telephone transmission is available with modem option only.***

To transmit records (either to another cardiograph or to E-Scribe), select the **XMT Key**; the following screen is displayed:

To batch transmit of all records in the directory, verify the transmit media selection in the configuration menu. Next go to the directory and select batch. If a batch transmission is selected, only those records which have not been previously transmitted or marked deleted will be transmitted.

An ECG may be listed in the directory but have a “deleted status” (indicated by “X”). The directory saves those records that have been marked for deletion in the event that you may want to recover the ECG at a later time. All stored ECGs will remain in the directory until it becomes full, at this time, the ELI 350 will automatically remove a record, the oldest record will be deleted first, in order to make room for the new ECG. Only those records that have been marked for deletion will be removed. Records are automatically marked for deletion based on the Delete Rule configuration. To manually mark an ECG record for deletion, go into the directory and choose the ECG you want to mark for deletion, then select delete from the options at the bottom of the screen.

To transmit one ECG, select the ECG from the patient directory, and choose the **XMT** soft key.

To quickly find and select a patient name, highlight a patient in the directory, use the keyboard to enter the first letter(s) of the last name. The desired name will automatically be highlighted. When the desired record is highlighted, transmit the individual ECG.

After the transmission of your record(s), the Real-Time ECG View is displayed.

**Serial Port Test (Direct connect transmission)**

For a direct connection hookup, connect the ELI 350 to another ELI 350 with a direct connect serial cable (Mortara P/N: 25000-024). Plug each end of the cable into the serial ports (RS232).

In the configuration setting, select a baud rate of 9600 or 38400 bps for both units.

See above section on Transmitting Records to perform the test transmission.

**Receive ECGs**

To receive ECGs from another Mortara Instrument electrocardiograph (using either a telephone or a direct connection), select **Receive** from the Menu on the left of the screen. The unit will then be ready to receive the ECG from the other unit. The LCD displays the following message: **Transmission Status Waiting to Receive Record.**

When the LCD displays the above message, the unit is ready to receive the ECGs from the transmitting electrocardiograph. Follow the instructions on transmitting records as described in this section. The receiving unit only acts as a printer. Received ECGs will not be viewed or stored. To terminate the receiving mode, choose **Cancel**.

**Note:** *The ELI 350 will only communicate with ELI 150, ELI 250 and ELI 350 units.*

## Modem Test

### *Modem Transmission*

For a modem transmission, connect the ELI 350 to a standard telephone jack with the provided phone line cable. Plug the cable into the telephone jack located on the back of the cardiograph and the other end into a telephone wall jack. Confirm telephone number in the configuration settings (see Section 3 of Operator's manual).

### *Modem Initialization*

The modem initialization string is country specific. At the time of production, the modem initialization string is configured for the country of purchase. However, if the unit is relocated to a different country, the modem initialization string will need to be modified. To change the modem country code, go to settings and enter **MODEM** in the password field. This will open the modem configuration screen. The modems country code can be changed from this screen.

Below is the list of the country codes supported at this time.

Country	Code	Country	Code
Argentina	07	Liechtenstein	68
Australia	09	Luxembourg	69
Austria	0A	Japan	00
Barbados	0E	Korea	61
Belgium	0F	Malaysia	6C
Brazil	16	Mexico	73
Canada	20	Netherlands	7B
Czech Republic	2E	New Zealand	7E
China	26	Norway	82
Denmark	31	Poland	8A
Finland	3C	Portugal	8B
France	3D	Russia	B8
Germany	04	South Africa	9F
Greece	46	Singapore	9C
Guam	48	Slovak Republic	FC
Hungary	51	Spain	A0
Hong Kong	50	Sweden	A5
Iceland	52	Switzerland	A6
India	53	Taiwan	FE
Indonesia	54	Thailand	A9
Ireland	57	United Kingdom	B4
Israel	58	United States	B5
Italy	59	Venezuela	BB

## Safety Tests

Please refer to the following industry standard documents for information regarding safety testing.

- ANSI/AAMI ES-1
- IEC 60601-1

The following tests are performed per the above specifications:

AC Hi-Pot Patient to Mains

Earth Leakage

Chassis Leakage

Patient Source

Patient Sink

## 5 Options and Upgrades

### *Upgrade Information*

Changing the options on an ELI 350 in the field is limited to software options; these options include, Interpretation, ECG storage capacity (200, 500 or 2000 ECG's) and communications (Serial Port only).

Hardware options such as Modem, LAN, and Wireless LAN, must be added at an Authorized Mortara Service Center.

Please contact Mortara Technical Support for the required files and process to perform these option upgrades.



Fig 5-1

Fig 5-1 above shows the ELI 350 motherboard with the Wireless LAN option installed.





Fig 5-2

Fig 5-2 above shows the ELI 350 motherboard with the Modem option installed.